

Type S Contactors and Starters

Class 8536/8502/8736/8702/8810/8811/8812



CONTENTS

Description	Page
Magnetic Contactors and Starters	1
Reversing Magnetic Starters and Contactors	25
Motor Starters Multi-Speed	39



SQUARE D
GROUPE SCHNEIDER

SECTION 1 – MAGNETIC CONTACTORS AND STARTERS

Application Data – Class 8502, 8536 2-3
Selection – Class 8502 4-7
Selection – Class 8536 8-12
Application Data – Class 8502, 8536 13-16
Approximate Dimensions, Shipping Weights – Class 8502, 8536 17-22
Application Data – Class 8502 Vacuum Contactors 23
Selection and Pricing – Class 8502 24



Full Voltage Contactors and Starters — NEMA Application Data – Class 8502, 8536



Type SCO2
Size 1, 3-Pole Contactor

AC MAGNETIC CONTACTORS CLASS 8502

General Information

Class 8502 Type S magnetic contactors are used to switch heating loads, capacitors, transformers, and electric motors where overload protection is separately provided. Class 8502 contactors are available in NEMA Sizes 00-7. Type S contactors are designed for operation at 600 Volts, AC 50-60 Hertz.

Holding Circuit Contact

A normally open holding circuit contact for three wire control is provided on all contactors as standard. Sizes 00-2 contactors use a Class 9999 SX11 auxiliary contact as the holding circuit contact. Sizes 3-7 contactors use a Class 9999 SX6 auxiliary contact as the holding circuit contact. See Class 9999 for the holding circuit contact electrical ratings. On Size 00-1 single phase contactors, a power pole is used as the holding circuit contact and therefore has the same rating as the power contacts.

Enclosures

Class 8502 magnetic contactors are available in the following enclosures:

- NEMA Type 1 General Purpose
- NEMA Type 4 & 4X Watertight and Dusttight Stainless Steel
- NEMA Type 4X Watertight, Dusttight, and Corrosion Resistant Glass — Polyester
- NEMA Type 7 & 9 Bolted and Spin-Top for Hazardous Locations
- NEMA Type 12 Dusttight and Driptight for Industrial Use

The NEMA Type 4 & 4X stainless steel enclosure (Sizes 0-5) has a brushed finish. For an electropolished finish, specify Form G16 and add 15% to the price of the standard device.

Also, NEMA Type 12 devices are available UL Listed for use in Class II, Division 2, Group G and Class III, Divisions 1 and 2 locations. Request Form G21, no additional charge.

Separate enclosures are available, see Class 9991.



Type SCO3
Size 1, 3-Pole Starter

AC MAGNETIC STARTERS CLASS 8536

General Information

Class 8536 Type S magnetic starters are used for full voltage starting and stopping AC squirrel cage motors. Motor overload protection is provided by melting alloy type thermal overload relays. Class 8536 starters are available in NEMA Sizes 00-7. Type S starters are designed for operation at 600 Volts AC, 50-60 Hertz.

Holding Circuit Contact

A normally open holding circuit contact for three wire control is provided on all contactors as standard. Sizes 00-2 contactors use a Class 9999 SX11 auxiliary contact as the holding circuit contact. Sizes 3-7 contactors use a Class 9999 SX6 auxiliary contact as the holding circuit contact. See Class 9999 for the holding circuit contact electrical ratings.

Overload Relays with Melting Alloys

Class 8536 Type S Sizes 00-6 starters are provided with a melting alloy thermal overload relay as standard. Interchangeable thermal units are available in standard trip (Class 20) Sizes 00-6, quick trip (Class 10) Sizes 00-4, and slow trip (Class 30) Sizes 00-3. Single-phase starters use one thermal unit, 3-phase starters use three thermal units.

Class 8536 Size 7 starters are provided with solid state Motor Logic which has selectable trip Class 10/20, Ground fault detection, and Communication capabilities for future enhancement. The solid state overload relay is ambient insensitive and features phase loss, phase unbalance and over-current protection.

MOTOR LOGIC™ Solid State Overload Relay (SSOLR)

Solid state overload relays are available for Sizes 00 – 7 starters. These ambient insensitive overload relays provide phase loss protection, phase unbalance protection and a LED power indicator. For additional information, see the Class 9065 catalog section. To order Type S starters with solid state overload relays, see Factory Modification (FORMS).

Bimetallic overload relays are also available for Sizes 0-6. Ambient Compensated and Non-compensated versions are supplied with manual



Starter with MOTOR LOGIC



Starter with Melting Alloy



Full Voltage Contactors and Starters — NEMA Application Data – Class 8502, 8536

and automatic reset, trip current adjustment, and an alarm contact on Sizes 0-2. For additional information, see the Class 9065 catalog section. To order Type S starters with bimetallic overload relays, see Factory Modifications (FORMS).

Enclosures

Class 8536 magnetic starters are available in the following enclosures.

- NEMA Type 1 General Purpose Enclosure
- NEMA Type 3R Rainproof, Sleet Resistant for Outdoor Use
- NEMA Type 4 & 4X Watertight and Dusttight
- NEMA Type 4X Watertight, Dusttight, and Corrosion Resistant Glass – Polyester
- NEMA Type 7 & 9 Bolted and Spin-Top for Hazardous Locations
- NEMA Type 9 Bolted for Hazardous Locations
- NEMA Type 12 Dusttight and Driptight for Industrial Use

The NEMA Type 4 & 4X stainless steel enclosure (Sizes 0-5) has a brushed finish. For an electropolished finish, specify Form G16 and add 15% to the price of the standard device. Sizes 6 & 7 are painted sheet steel and are rated NEMA 4 ONLY.

Also NEMA Type 12 devices are available UL Listed for use in Class II, Division 2, Group G and Class III, Divisions 1 and 2 locations. Specify Form G21, no additional charge.

Separate enclosures are available, see Class 9991.

Coil Voltages

AC coils are available for application on 50-60 Hertz. NEMA Sizes 00-5 are supplied with coils that are designed to operate satisfactorily on line voltages of 85% – 110% of rated voltage. NEMA Size 6 and 7 contactors are supplied with a DC coil operated by a solid state rectifier circuit that is powered by an AC source.

Please note that **Voltage Codes** have been added to the Type designations in order to improve customer service. It is necessary to include the Voltage Code when ordering contactors and starters. Also, 120 Volt Polyphase contactors and starters will be wired for separate control.

Auxiliary Contacts

Additional auxiliary contacts may be added to Type S contactors. See Page 15 for maximum number of auxiliary units and Form designations for factory installed auxiliary contacts.

Type S Accessories

Additional accessories such as power poles, pneumatic timer attachments, and cover mounted control stations are available as factory or field modifications.



Full Voltage Contactors — NEMA Selection — Class 8502



Type SC02
Size 1, 3-Pole Contactor

3-Pole Polyphase — 600 Volts AC Maximum — 50-60 Hertz

NEMA Size	Continuous Current Ratings	Motor Volts	Max. HP	* Coil Voltage	Open Type	NEMA Type 1 General Purpose Enclosure	NEMA Type 4 & 4X Watertight, Dusttight Brushed Stainless Steel Enclosure (Size 0-5)♦
					Type	Type	Type
00	9	Separate Control†		120	SAO12V02S	SAG12V02S	USE Size 0
		200	1½	208	SAO12V08	SAG12V08	
		230	1½	240	SAO12V03	SAG12V03	
		460	2	480	SAO12V06	SAG12V06	
		575	2	600	SAO12V07	SAG12V07	
0	18	Separate Control†		120	SBO2V02S	SBG2V02S	SBW12V02S
		200	3	208	SBO2V08	SBG2V08	SBW12V08
		230	3	240	SBO2V03	SBG2V03	SBW12V03
		460	5	480	SBO2V06	SBG2V06	SBW12V06
		575	5	600	SBO2V07	SBG2V07	SBW12V07
1	27	Separate Control†		120	SCO2V02S	SCG2V02S	SCW12V02S
		200	7½	208	SCO2V08	SCG2V08	SCW12V08
		230	7½	240	SCO2V03	SCG2V03	SCW12V03
		460	10	480	SCO2V06	SCG2V06	SCW12V06
		575	10	600	SCO2V07	SCG2V07	SCW12V07
2	45	Separate Control†		120	SDO2V02S	SDG2V02S	SDW12V02S
		200	10	208	SDO2V08	SDG2V08	SDW12V08
		230	15	240	SDO2V03	SDG2V03	SDW12V03
		460	25	480	SDO2V06	SDG2V06	SDW12V06
		575	25	600	SDO2V07	SDG2V07	SDW12V07
3	90	Separate Control†		120	SEO2V02S	SEG2V02S	SEW12V02S
		200	25	208	SEO2V08	SEG2V08	SEW12V08
		230	30	240	SEO2V03	SEG2V03	SEW12V03
		460	50	480	SEO2V06	SEG2V06	SEW12V06
		575	50	600	SEO2V07	SEG2V07	SEW12V07
4	135	Separate Control†		120	SFO2V02S	SFG2V02S	SFW12V02S
		200	40	208	SFO2V08	SFG2V08	SFW12V08
		230	50	240	SFO2V03	SFG2V03	SFW12V03
		460	100	480	SFO2V06	SFG2V06	SFW12V06
		575	100	600	SFO2V07	SFG2V07	SFW12V07
5	270	Separate Control†		120	SGO2V02S	SGG2V02S	SGW12V02S
		200	75	208	SGO2V08	SGG2V08	SGW12V08
		230	100	240	SGO2V03	SGG2V03	SGW12V03
		460	200	480	SGO2V06	SGG2V06	SGW12V06
		575	200	600	SGO2V07	SGG2V07	SGW12V07
6	540	Separate Control†		120	SHO2V02S	SHG2V02S	SHW12V02S
		200	150	208	SHO2V08	SHG2V08	SHW12V08
		230	200	240	SHO2V03	SHG2V03	SHW12V03
		460	400	480	SHO2V06	SHG2V06	SHW12V06
		575	400	600	SHO2V07	SHG2V07	SHW12V07
7	810	Separate Control†		120	SJO2V02S	SJG2V02S	SJW12V02S
		200	...	208	SJO2V08	SJG2V08	SJW12V08
		230	300	240	SJO2V03	SJG2V03	SJW12V03
		460	600	480	SJO2V06	SJG2V06	SJW12V06
		575	600	600	SJO2V07	SJG2V07	SJW12V07

♦ Size 6 and 7 are painted sheet steel rated NEMA Type 4 only.

† 120 Volt Polyphase contactors are wired for separate control.

* Coil voltage code must be specified to order this product. Refer to standard voltage codes listed below and insert as shown in How to Order.

Coil Voltage Codes

Voltage		Code
60 Hz	50 Hz	
24▲	...	VO1
120	110	VO2
208	...	VO8
240	220	VO3
480	440	VO6
600	550	VO7
Specify	Specify	V99

▲ 24 V coils are not available on Sizes 4-7. On Sizes 00-3, where 24 V coils are available, Form S (separate control) must be specified.

How to Order:

To Order Specify:	Catalog Number			
• Class Number	Class	Type	Coil Voltage Code	Form(s)
• Type Number				
• Coil Voltage Code				
• Form(s)				
	8502	SBG2	VO2	P1S

Factory Modifications (FORMS)Refer to Catalog 9999CT9701
Application Data Pages 13-16
Dimensions Pages 17-20
Separate Enclosures (Class 9991)Refer to Catalog 9999CT9701
Replacement Parts (Class 9998)Refer to Catalog 9999CT9701
Type S Accessories (Class 9999)Refer to Catalog 9999CT9701



File E78351
CCN NLDX



File LR12751
Class 3211-04



File 60905
Class 3211-04



IEC 947-4-1
Sizes 00-5 only



Full Voltage Contactors — NEMA Selection – Class 8502

3-Pole Polyphase — 600 Volts AC Maximum — 50-60 Hertz

NEMA Size	Continuous Current Ratings	Motor Volts	Max. HP	* Coil Voltage	NEMA Type 4X Watertight, Dusttight, Corrosion-Resistant Glass-Polyester Enclosure	NEMA Type 7 & 9 Hazardous Locations Class I, Groups C & D Class II, Groups E, F, & G			NEMA Type 12 Dusttight & Driptight Industrial Use Enclosure
					Type	Bolted Type		SPIN TOP® Type	Type
						Cast Iron■	Cast Aluminum		
00	9	Separate Control 200 1½ 230 1½ 460 2 575 2	120 208 240 480 600	Use Size 0	Use Size 0	Use Size 0	Use Size 0	Use Size 0	
0	18	Separate Control 200 3 230 3 460 5 575 5	120 208 240 480 600	SBW22V02S SBW22V08 SBW22V03 SBW22V06 SBW22V07	SBT2V02S SBT2V08 SBT2V03 SBT2V06 SBT2V07	SBT42V02S SBT42V08 SBT42V03 SBT42V06 SBT42V07	SBR2V02S SBR2V08 SBR2V03 SBR2V06 SBR2V07	SBA2V02S SBA2V08 SBA2V03 SBA2V06 SBA2V07	
1	27	Separate Control 200 7½ 230 7½ 460 10 575 10	120 208 240 480 600	SCW22V02S SCW22V08 SCW22V03 SCW22V06 SCW22V07	SCT2V02S SCT2V08 SCT2V03 SCT2V06 SCT2V07	SCT42V02S SCT42V08 SCT42V03 SCT42V06 SCT42V07	SCR2V02S SCR2V08 SCR2V03 SCR2V06 SCR2V07	SCA2V02S SCA2V08 SCA2V03 SCA2V06 SCA2V07	
2	45	Separate Control 200 10 230 15 460 25 575 25	120 208 240 480 600	SDW22V02S SDW22V08 SDW22V03 SDW22V06 SDW22V07	SdT2V02S SdT2V08 SdT2V03 SdT2V06 SdT2V07	SdT42V02S SdT42V08 SdT42V03 SdT42V06 SdT42V07	SDR2V02S SDR2V08 SDR2V03 SDR2V06 SDR2V07	SDA2V02S SDA2V08 SDA2V03 SDA2V06 SDA2V07	
3	90	Separate Control 200 25 230 30 460 50 575 50	120 208 240 480 600	SEW22V02S SEW22V08 SEW22V03 SEW22V06 SEW22V07	...	SET42V02S SET42V08 SET42V03 SET42V06 SET42V07	SER2V02S SER2V08 SER2V03 SER2V06 SER2V07	SEA2V02S SEA2V08 SEA2V03 SEA2V06 SEA2V07	
4	135	Separate Control 200 40 230 50 460 100 575 100	120 208 240 480 600	SFW22V02S SFW22V08 SFW22V03 SFW22V06 SFW22V07	...	SFT42V02S SFT42V08 SFT42V03 SFT42V06 SFT42V07	SFR2V02S SFR2V08 SFR2V03 SFR2V06 SFR2V07	SFA2V02S SFA2V08 SFA2V03 SFA2V06 SFA2V07	
5	270	Separate Control 200 75 230 100 460 200 575 200	120 208 240 480 600	SGR2V02S SGR2V08 SGR2V03 SGR2V06 SGR2V07	SGA2V02S SGA2V08 SGA2V03 SGA2V06 SGA2V07	
6	540	Separate Control 200 150 230 200 460 400 575 400	120 208 240 480 600	SHA2V02S SHA2V08 SHA2V03 SHA2V06 SHA2V07	
7	810	Separate Control 200 — 230 300 460 600 575 600	208 240 480 600	SJA2V02S SJA2V08 SJA2V03 SJA2V06 SJA2V07	

† 120 Volt Polyphase contactors are wired for separate control.

■ Limited to one Pilot Light and a Selector Switch or Start-Stop Push Button.

* Coil voltage code must be specified to order this product. Refer to standard coil voltage codes listed in selection table above or additional standard voltage codes below and insert as shown in the HOW TO ORDER block.

Coil Voltage Codes

Voltage		Code
60 Hz	50 Hz	
24▲	...	VO1
120	110	VO2
208	...	VO8
240	220	VO3
480	440	VO6
600	550	VO7
Specify	Specify	V99

▲ 24 V coils are not available on Sizes 4-7. On Sizes 00-3, where 24 V coils are available, Form S (separate control) must be specified.

Explosion Proof Units



File E78503
CCN NPKR



File LR60905
Class 3218-03

How to Order:

To Order Specify:	Catalog Number			
<ul style="list-style-type: none"> • Class Number • Type Number • Coil Voltage Code • Form(s) 	Class	Type	Coil Voltage Code	Form(s)
	8502	SBA2	VO2	P1S

Factory Modifications (FORMS)..... Refer to Catalog 9999CT9701
 Application Data..... Pages 13-16
 Dimensions..... Pages 17-20
 Separate Enclosures (Class 9991)..... Refer to Catalog 9999CT9701
 Replacement Parts (Class 9998)..... Refer to Catalog 9999CT9701
 Type S Accessories (Class 9999)..... Refer to Catalog 9999CT9701



Full Voltage Contactors — NEMA Selection – Class 8502

600 Volts AC Maximum — 50-60 Hertz

NEMA Size	Continuous Current Ratings	Motor Volts	Max. HP	* Coil Voltage	Open Type	NEMA Type 1 General Purpose Enclosure	NEMA Type 4 & 4X Watertight, Dusttight Brushed Stainless Steel Enclosure (Size 0-5)♦
					Type	Type	Type
1-Pole Single Phase							
0	18	115 230	1 2	120 240	SBO5V02 SBO5V03	SBG5V02 SBG5V03	SBW15V02 SBW15V03
1	27	115 230	2 3	120 240	SCO5V02 SCO5V03	SCG5V02 SCG5V03	SCW15V02 SCW15V03
2-Pole Single Phase							
00	9	115 230	1/3 1	120 240	SAO11V02 SAO11V03	SAG11V02 SAG11V03	Use Size 0
0	18	115 230	1 2	120 240	SBO1V02 SBO1V03	SBG1V02 SBG1V03	SBW11V02 SBW11V03
1	27	115 230	2 3	120 240	SCO1V02 SCO1V03	SCG1V02 SCG1V03	SCW11V02 SCW11V03
2	45	115 230	3 7 1/2	120 240	SDO1V02 SDO1V03	SDG1V02 SDG1V03	SDW11V02 SDW11V03
3	90	120 240	SEO1V02 SEO1V03	SEG1V02 SEG1V03	SEW11V02 SEW11V03
4	135	120 240	SFO1V02 SFO1V03	SFG1V02 SFG1V03	SFW11V02 SFW11V03
5	270	120 240	SGO1V02 SGO1V03	SGG1V02 SGG1V03	SGW11V02 SGW11V03
6	540	120 240	SHO1V02 SHO1V03	SHG1V02 SHG1V03	SHW11V02 SHW11V03
7	810	120 240	SJO1V02 SJO1V03	SJG1V02 SJG1V03	SJW11V02 SJW11V03
4-Pole Polyphase							
0	18	Separate Control† 200 230 460 575	3 3 5 5	120 208 240 480 600	SBO3V02S SBO3V08 SBO3V03 SBO3V06 SBO3V07	SBG3V02S SBG3V08 SBG3V03 SBG3V06 SBG3V07	SBW13V02S SBW13V08 SBW13V03 SBW13V06 SBW13V07
1	27	Separate Control† 200 230 460 575	7 1/2 7 1/2 10 10	120 208 240 480 600	SCO3V02S SCO3V08 SCO3V03 SCO3V06 SCO3V07	SCG3V02S SCG3V08 SCG3V03 SCG3V06 SCG3V07	SCW13V02S SCW13V08 SCW13V03 SCW13V06 SCW13V07
2	45	Separate Control† 200 230 460 575	10 15 25 25	120 208 240 480 600	SDO3V02S SDO3V08 SDO3V03 SDO3V06 SDO3V07	SDG3V02S SDG3V08 SDG3V03 SDG3V06 SDG3V07	SDW13V02S SDW13V08 SDW13V03 SDW13V06 SDW13V07
3	90	Separate Control† 200 230 460 575	25 30 50 50	120 208 240 480 600	SEO3V02S SEO3V08 SEO3V03 SEO3V06 SEO3V07	SEG3V02S SEG3V08 SEG3V03 SEG3V06 SEG3V07	SEW13V02S SEW13V08 SEW13V03 SEW13V06 SEW13V07
4	135	Separate Control† 200 230 460 575	40 50 100 100	120 208 240 480 600	SFO3V02S SFO3V08 SFO3V03 SFO3V06 SFO3V07	SFG3V02S SFG3V08 SFG3V03 SFG3V06 SFG3V07	SFW13V02S SFW13V08 SFW13V03 SFW13V06 SFW13V07
5-Pole Polyphase							
0	18	Separate Control† 200 230 460 575	3 3 5 5	120 208 240 480 600	SBO4V02S SBO4V08 SBO4V03 SBO4V06 SBO4V07	SBG4V02S SBG4V08 SBG4V03 SBG4V06 SBG4V07	SBW14V02S SBW14V08 SBW14V03 SBW14V06 SBW14V07
1	27	Separate Control† 200 230 460 575	7 1/2 7 1/2 10 10	120 208 240 480 600	SCO4V02S SCO4V08 SCO4V03 SCO4V06 SCO4V07	SCG4V02S SCG4V08 SCG4V03 SCG4V06 SCG4V07	SCW14V02S SCW14V08 SCW14V03 SCW14V06 SCW14V07
2	45	Separate Control† 200 230 460 575	10 15 25 25	120 208 240 480 600	SDO4V02S SDO4V08 SDO4V03 SDO4V06 SDO4V07	SDG4V02S SDG4V08 SDG4V03 SDG4V06 SDG4V07	SDW14V02S SDW14V08 SDW14V03 SDW14V06 SDW14V07
3	90	Separate Control† 200 230 460 575	25 30 50 50	120 208 240 480 600	SEO4V02S SEO4V08 SEO4V03 SEO4V06 SEO4V07	SEG4V02S SEG4V08 SEG4V03 SEG4V06 SEG4V07	SEW14V02S SEW14V08 SEW14V03 SEW14V06 SEW14V07
4	135	Separate Control† 200 230 460 575	40 50 100 100	120 208 240 480 600	SFO4V02S SFO4V08 SFO4V03 SFO4V06 SFO4V07	SFG4V02S SFG4V08 SFG4V03 SFG4V06 SFG4V07	SFW14V02S SFW14V08 SFW14V03 SFW14V06 SFW14V07

♦ Size 6 and 7 are painted sheet steel rated NEMA Type 4 only.

† 120 Volt Polyphase contactors are wired for separate control.

* Coil voltage code must be specified to order this product. Refer to standard voltage codes listed in selection table above or additional standard voltage codes and insert as shown in the HOW TO ORDER block on Page 5.



Full Voltage Contactors — NEMA Selection – Class 8502

600 Volts AC Maximum — 50-60 Hertz

NEMA Size	Continuous Current Ratings	Motor Volts	Max. HP	* Coil Voltage	NEMA Type 4X Watertight, Dusttight, Corrosion-Resistant Glass-Polyester Enclosure	NEMA Type 7 & 9 Hazardous Locations Class I, Groups C & D Class II, Groups E, F, & G			NEMA Type 12 Dusttight & Driptight Industrial Use Enclosure
					Type	Bolted Type		SPIN TOP® Type	Type
						Cast Iron■	Cast Aluminum		
1-Pole Single Phase									
0	18	115 230	1 2	120 240	...	SBT5V02 SBT5V03	SBT45V02 SBT45V03	SBR5V02 SBR5V03	SBA5V02 SBA5V03
1	27	115 230	2 3	120 240	...	SCT5V02 SCT5V03	SCT45V02 SCT45V03	SCR5V02 SCR5V03	SCA5V02 SCA5V03
2-Pole Single Phase									
00	9	115 230	1/3 1	120 240	Use Size 0	Use Size 0	Use Size 0	Use Size 0	Use Size 0
0	18	115 230	1 2	120 240	SBW21V02 SBW21V03	SBT1V02 SBT1V03	SBT41V02 SBT41V03	SBR1V02 SBR1V03	SBA1V02 SBA1V03
1	27	115 230	2 3	120 240	SCW21V02 SCW21V03	SCT1V02 SCT1V03	SCT41V02 SCT41V03	SCR1V02 SCR1V03	SCA1V02 SCA1V03
2	45	115 230	3 7½	120 240	SDW21V02 SDW21V03	SDT1V02 SDT1V03	SDT41V02 SDT41V03	SDR1V02 SDR1V03	SDA1V02 SDA1V03
3	90	120 240	Consult Local Square D Field Office	...	SET41V02 SET41V03	SER1V02 SER1V03	SEA1V02 SEA1V03
4	135	120 240	Consult Local Square D Field Office	...	SFT41V02 SFT41V03	SFR1V02 SFR1V03	SFA1V02 SFA1V03
5	270	120 240	SGR1V02 SGR1V03	SGA1V02 SGA1V03
6	540	120 240	SHA1V02 SHA1V03
7	810	120 240	SJA1V02 SJA1V03
4-Pole Polyphase									
0	18	Separate Control 200 3 230 3 460 5 575 5	120 208 240 480 600	SBW33V02S SBW33V08 SBW33V03 SBW33V06 SBW33V07	SBT3V02S SBT3V08 SBT3V03 SBT3V06 SBT3V07	Consult Local Square D Field Office	SBR3V02S SBR3V08 SBR3V03 SBR3V06 SBR3V07	SBA3V02S SBA3V08 SBA3V03 SBA3V06 SBA3V07	
1	27	Separate Control 200 7½ 230 7½ 460 10 575 19	120 208 240 480 600	SCW23V02S SCW23V08 SCW23V03 SCW23V06 SCW23V07	SCT3V02S SCT3V08 SCT3V03 SCT3V06 SCT3V07	Consult Local Square D Field Office	SCR3V02S SCR3V08 SCR3V03 SCR3V06 SCR3V07	SCA3V02S SCA3V08 SCA3V03 SCA3V06 SCA3V07	
2	45	Separate Control 200 10 230 15 460 25 575 25	120 208 240 480 600	SDW23V02S SDW23V08 SDW23V03 SDW23V06 SDW23V07	SDT3V02S SDT3V08 SDT3V03 SDT3V06 SDT3V07	Consult Local Square D Field Office	SDR3V02S SDR3V08 SDR3V03 SDR3V06 SDR3V07	SDA3V02S SDA3V08 SDA3V03 SDA3V06 SDA3V07	
3	90	Separate Control 200 25 230 30 460 50 575 50	120 208 240 480 600	Consult Local Square D Field Office	Consult Local Square D Field Office	Consult Local Square D Field Office	SER3V02S SER3V08 SER3V03 SER3V06 SER3V07	SEA3V02S SEA3V08 SEA3V03 SEA3V06 SEA3V07	
4	135	Separate Control 200 40 230 50 460 100 575 100	120 208 240 480 600	Consult Local Square D Field Office	Consult Local Square D Field Office	Consult Local Square D Field Office	SFR3V02S SFR3V08 SFR3V03 SFR3V06 SFR3V07	SFA3V02S SFA3V08 SFA3V03 SFA3V06 SFA3V07	
5-Pole Polyphase									
0	18	Separate Control 200 3 230 3 460 5 575 5	120 208 240 480 600	Consult Local Square D Field Office	SBA4V02S SBA4V08 SBA4V03 SBA4V06 SBA4V07	
1	27	Separate Control 200 7½ 230 7½ 460 10 575 10	120 208 240 480 600	Consult Local Square D Field Office	SCA4V02S SCA4V08 SCA4V03 SCA4V06 SCA4V07	
2	45	Separate Control 200 10 230 15 460 25 575 25	120 208 240 480 600	Consult Local Square D Field Office	SDA4V02S SDA4V08 SDA4V03 SDA4V06 SDA4V07	
3	90	Separate Control 200 25 230 30 460 50 575 50	120 208 240 480 600	Consult Local Square D Field Office	SEA4V02S SEA4V08 SEA4V03 SEA4V06 SEA4V07	
4	135	Separate Control 200 40 230 50 460 100 575 100	120 208 240 480 600	Consult Local Square D Field Office	SFA4V02S SFA4V08 SFA4V03 SFA4V06 SFA4V07	

† 120 Volt Polyphase contactors are wired for separate control.

■ Limited to one Pilot Light and a Selector Switch or Start-Stop Push Button.

* Coil voltage code must be specified to order this product. Refer to standard coil voltage codes listed in selection table above or additional standard voltage codes and insert as shown in the HOW TO ORDER block on Page 5.



Full Voltage Starters — NEMA Selection – Class 8536

3-Pole Polyphase—600 Volt AC Max. 50/60 Hz—Three Thermal Units Required

NEMA Size	Continuous Current Ratings	Motor Volts	Max. HP	* Coil Voltage	Open Type	NEMA Type 1 General Purpose Enclosure	NEMA Type 4 & 4X Watertight, Dusttight Brushed Stainless Steel Enclosure (Size 0-5)†	NEMA Type 4X Watertight, Dusttight, Corrosion-Resistant Glass-Polyester Enclosure
					Type	Type	Type	Type
00	9	Separate Control	1 1/2	120	SAO12V02S	SAG12V02S	Use Size 0	Use Size 0
		200		SAO12V08	SAG12V08			
		230		SAO12V03	SAG12V03			
		460		SAO12V06	SAG12V06			
		575		SAO12V07	SAG12V07			
0	18	Separate Control	3	120	SBO2V02S	SBG2V02S	SBW12V02S	SBW22V02S
		200		SBO2V08	SBG2V08	SBW12V08	SBW22V08	
		230		SBO2V03	SBG2V03	SBW12V03	SBW22V03	
		460		SBO2V06	SBG2V06	SBW12V06	SBW22V06	
		575		SBO2V07	SBG2V07	SBW12V07	SBW22V07	
1	27	Separate Control	7 1/2	120	SCO3V02S	SCG3V02S	SCW13V02S	SCW23V02S
		200		SCO3V08	SCG3V08	SCW13V08	SCW23V08	
		230		SCO3V03	SCG3V03	SCW13V03	SCW23V03	
		460		SCO3V06	SCG3V06	SCW13V06	SCW23V06	
		575		SCO3V07	SCG3V07	SCW13V07	SCW23V07	
2	45	Separate Control	10	120	SDO1V02S	SDG1V02S	SDW11V02S	SDW21V02S
		200		SDO1V08	SDG1V08	SDW11V08	SDW21V08	
		230		SDO1V03	SDG1V03	SDW11V03	SDW21V03	
		460		SDO1V06	SDG1V06	SDW11V06	SDW21V06	
		575		SDO1V07	SDG1V07	SDW11V07	SDW21V07	
3	90	Separate Control	25	120	SEO1V02S	SEG1V02S	SEW11V02S	SEW21V02S
		200		SEO1V08	SEG1V08	SEW11V08	SEW21V08	
		230		SEO1V03	SEG1V03	SEW11V03	SEW21V03	
		460		SEO1V06	SEG1V06	SEW11V06	SEW21V06	
		575		SEO1V07	SEG1V07	SEW11V07	SEW21V07	
4	135	Separate Control	40	120	SFO1V02S	SFG1V02S	SFW11V02S	SFW21V02S
		200		SFO1V08	SFG1V08	SFW11V08	SFW21V08	
		230		SFO1V03	SFG1V03	SFW11V03	SFW21V03	
		460		SFO1V06	SFG1V06	SFW11V06	SFW21V06	
		575		SFO1V07	SFG1V07	SFW11V07	SFW21V07	
5	270	Separate Control	75	120	SGO1V02S	SGG1V02S	SGW11V02S	...
		200		SGO1V08	SGG1V08	SGW11V08	...	
		230		SGO1V03	SGG1V03	SGW11V03	...	
		460		SGO1V06	SGG1V06	SGW11V06	...	
		575		SGO1V07	SGG1V07	SGW11V07	...	
6	540	Separate Control	150	120	SHO2V02S	SHG2V02S	SHW2V02S	...
		200		SHO2V08	SHG2V08	SHW2V08	...	
		230		SHO2V03	SHG2V03	SHW2V03	...	
		460		SHO2V06	SHG2V06	SHW2V06	...	
		575		SHO2V07	SHG2V07	SHW2V07	...	
7	810	Separate Control	300	120	SJO2V02S	SJG2V02S	SJW2V02S	...
		200		SJO2V08	SJG2V08	SJW2V08	...	
		230		SJO2V03	SJG2V03	SJW2V03	...	
		460		SJO2V06	SJG2V06	SJW2V06	...	
		575		SJO2V07	SJG2V07	SJW2V07	...	

† Size 6 and 7 are rated NEMA Type 4 only.
 † 120 Volt Polyphase starters are wired for separate control.
 * Coil voltage code must be specified to order this product. Refer to standard coil voltage codes listed in selection table above or additional standard voltage codes below and insert as shown in the HOW TO ORDER block.

Coil Voltage Codes

Voltage		Code
60 Hz	50 Hz	
24▲	...	VO1
120	110	VO2
208	...	VO8
240	220	VO3
480	440	VO6
600	550	VO7
Specify	Specify	V99

▲ 24 V coils are not available on Sizes 4-7. On Sizes 00-3, where 24 V coils are available, Form S (separate control) must be specified.

How to Order:

To Order Specify: • Class Number • Type Number • Coil Voltage Code • Form(s)	Catalog Number			
	Class	Type	Coil Voltage Code	Form(s)
	8536	SBA2	VO2	P1S

Factory Modifications (FORMS)Refer to Catalog 9999CT9701
Application Data Pages 13-16
Dimensions Pages 17-20
Separate Enclosures (Class 9991)Refer to Catalog 9999CT9701
Replacement Parts (Class 9998)Refer to Catalog 9999CT9701
Type S Accessories (Class 9999)Refer to Catalog 9999CT9701



File E78351
CCN NLDX



File LR60905
Class 3211-04



IEC 947-4-1
Sizes 00-5 only



Full Voltage Starters — NEMA Selection – Class 8536

3-Pole Polyphase — 600 Volts AC Maximum — 50-60 Hertz—Three Thermal Units Required

NEMA Size	Continuous Current Ratings	Motor Volts	Max. HP	* Coil Voltage	NEMA Type 7 & 9 Hazardous Locations Class I, Groups C & D Class II, Class E, F, & G		SPIN TOP® Type	NEMA Type 9 Hazardous Locations Class II, Groups E, F, & G		NEMA Type 12/3R® Dusttight & Driptight Industrial Use Enclosure	
					Bolted Type			Type	Type		
					Cast Iron■	Cast Aluminum					
00	9	Separate Control† 200 1½ 230 1½ 460 2 575 2	120 208 240 480 600	USE Size 0	USE Size 0	USE Size 0	USE Size 0	USE Size 0	USE Size 0	USE Size 0	
0	18	Separate Control† 200 3 230 3 460 5 575 5	120 208 240 480 600	SBT2V02S SBT2V08 SBT2V03 SBT2V06 SBT2V07	SBT42V02S SBT42V08 SBT42V03 SBT42V06 SBT42V07	SBR2V02S SBR2V08 SBR2V03 SBR2V06 SBR2V07	SBE2V02S SBE2V08 SBE2V03 SBE2V06 SBE2V07	SBA2V02S SBA2V08 SBA2V03 SBA2V06 SBA2V07			
1	27	Separate Control† 200 7½ 230 7½ 460 10 575 10	120 208 240 480 600	SCT3V02S SCT3V08 SCT3V03 SCT3V06 SCT3V07	SCT43V02S SCT43V08 SCT43V03 SCT43V06 SCT43V07	SCR3V02S SCR3V08 SCR3V03 SCR3V06 SCR3V07	SCE3V02S SCE3V08 SCE3V03 SCE3V06 SCE3V07	SCA3V02S SCA3V08 SCA3V03 SCA3V06 SCA3V07			
2	45	Separate Control† 200 10 230 15 460 25 575 25	120 208 240 480 600	SDT1V02S SDT1V08 SDT1V03 SDT1V06 SDT1V07	SDT41V02S SDT41V08 SDT41V03 SDT41V06 SDT41V07	SDR1V02S SDR1V08 SDR1V03 SDR1V06 SDR1V07	SDE1V02S SDE1V08 SDE1V03 SDE1V06 SDE1V07	SDA1V02S SDA1V08 SDA1V03 SDA1V06 SDA1V07			
3	90	Separate Control† 200 25 230 30 460 50 575 50	120 208 240 480 600	...	SET43V02S SET43V08 SET43V03 SET43V06 SET43V07	SER3V02S SER3V08 SER3V03 SER3V06 SER3V07	SEE1V02S SEE1V08 SEE1V03 SEE1V06 SEE1V07	SEA1V02S SEA1V08 SEA1V03 SEA1V06 SEA1V07			
4	135	Separate Control† 200 40 230 50 460 100 575 100	120 208 240 480 600	...	SFT41V02S SFT41V08 SFT41V03 SFT41V06 SFT41V07	SFR1V02S SFR1V08 SFR1V03 SFR1V06 SFR1V07	SFE1V02S SFE1V08 SFE1V03 SFE1V06 SFE1V07	SFA1V02S SFA1V08 SFA1V03 SFA1V06 SFA1V07			
5	270	Separate Control† 200 75 230 100 460 200 575 200	120 208 240 480 600	...	SGT41V02S SGT41V08 SGT41V03 SGT41V06 SGT41V07	SGR1V02S SGR1V08 SGR1V03 SGR1V06 SGR1V07	SGE1V02S SGE1V08 SGE1V03 SGE1V06 SGE1V07	SGA1V02S SGA1V08 SGA1V03 SGA1V06 SGA1V07			
6	540	Separate Control† 200 150 230 200 460 400 575 400	120 208 240 480 600	SHA2V02S SHA2V08 SHA2V03 SHA2V06 SHA2V07			
7	810	Separate Control† 200 — 230 300 460 600 575 600	120 208 240 480 600	SJA2V02S SJA2V08 SJA2V03 SJA2V06 SJA2V07			

- For NEMA Type 3R enclosed devices (Sizes 0-4 only), change "A" in Type designation to "H", no additional charge. Consult Factory for restrictions on available Forms in NEMA Type 3R enclosures.
- † 120 Volt Polyphase starters are wired for separate control.
- Limited to one Pilot Light and a Selector Switch or Start-Stop Push Button.
- * Coil voltage code must be specified to order this product. Refer to standard coil voltage codes listed in selection table above or additional standard voltage codes in table below and insert as shown in the HOW TO ORDER block.

Coil Voltage Codes

Voltage		Code
60 Hz	50 Hz	
24▲	...	VO1
120	110	VO2
208	...	VO8
240	220	VO3
480	440	VO6
600	550	VO7
Specify	Specify	V99

- ▲ 24 V coils are not available on Sizes 4-7. On Sizes 00-3, where 24 V coils are available, Form S (separate control) must be specified.

Factory Modifications (FORMS)..... Refer to Catalog 9999CT9701
 Application Data..... Pages 13-16
 Dimensions..... Pages 17-20
 Separate Enclosures (Class 9991)..... Refer to Catalog 9999CT9701
 Replacement Parts (Class 9998)..... Refer to Catalog 9999CT9701
 Type S Accessories (Class 9999)..... Refer to Catalog 9999CT9701

How to Order:

To Order Specify:	Catalog Number			
<ul style="list-style-type: none"> • Class Number • Type Number • Coil Voltage Code • Form(s) 	Class	Type	Coil Voltage Code	Form(s)
	8536	SBA2	VO2	H30



Full Voltage Starters — NEMA Selection — Class 8536

2-Pole Single Phase — 600 Volts AC Maximum — 50-60 Hertz Thermal Units — One Thermal Unit Required

NEMA Size	Continuous Current Ratings	Motor Volts	Max. HP	* Coil Voltage	Open Type	NEMA Type 1 General Purpose Enclosure	NEMA Type 4 & 4X Watertight, Dusttight Brushed Stainless Steel Enclosure	NEMA Type 4X Watertight, Dusttight, Corrosion-Resistant Glass-Polyester Enclosure
					Type	Type	Type	Type
00	9	115 230	1/3 1	120 240	SAO11V02 SAO11V03	SAG11V02 SAG11V03	Use Size 0	Use Size 0
0	18	115 230	1 2	120 240	SBO1V02 SBO1V03	SBG1V02 SBG1V03	SBW11V02 SBW11V03	SBW21V02 SBW21V03
1	27	115 230	2 3	120 240	SCO1V02 SCO1V03	SCG1V02 SCG1V03	SCW11V02 SCW11V03	SCW21V02 SCW21V03
1P	36	115 230	3 5	120 240	SCO2V02 SCO2V03	SCG2V02 SCG2V03	SCW12V02 SCW12V03	SCW22V02 SCW22V03
2	45	115 230	3 7 1/2	120 240	SDO6V02 SDO6V03	SDG6V02 SDG6V03	SDW16V02 SDW16V03	SDW26V02 SDW26V03

4-Pole, 2-Phase — 600 Volts AC Maximum — 50-60 Hertz — Two Thermal Units Required

NEMA Size	Continuous Current Ratings	Motor Volts	Max. HP	* Coil Voltage	Open Type	NEMA Type 1 General Purpose Enclosure	NEMA Type 4 & 4X Watertight, Dusttight Brushed Stainless Steel Enclosure	NEMA Type 4X Watertight, Dusttight, Corrosion-Resistant Glass-Polyester Enclosure
					Type	Type	Type	Type
0	18	Separate Control† 200 230 460 575	Control† 3 3 10 10	120	SBO3V02S	SBG3V02S	SBW13V02S	SBW23V02S
				208	SBO3V08	SBG3V08	SBW13V08	SBW23V08
				240	SBO3V03	SBG3V03	SBW13V03	SBW23V03
				480	SBO3V06	SBG3V06	SBW13V06	SBW23V06
				600	SBO3V07	SBG3V07	SBW13V07	SBW23V07
1	27	Separate Control† 200 230 460 575	Control† 7 1/2 7 1/2 10 10	120	SCO4V02S	SCG4V02S	SCW14V02S	SCW24V02S
				208	SCO4V08	SCG4V08	SCW14V08	SCW24V08
				240	SCO4V03	SCG4V03	SCW14V03	SCW24V03
				480	SCO4V06	SCG4V06	SCW14V06	SCW24V06
				600	SCO4V07	SCG4V07	SCW14V07	SCW24V07
2	45	Separate Control† 200 230 460 575	Control† 10 15 25 25	120	SDO2V02S	SDG2V02S	SDW12V02S	SDW22V02S
				208	SDO2V08	SDG2V08	SDW12V08	SDW22V08
				240	SDO2V03	SDG2V03	SDW12V03	SDW22V03
				480	SDO2V06	SDG2V06	SDW12V06	SDW22V06
				600	SDO2V07	SDG2V07	SDW12V07	SDW22V07
3	90	Separate Control† 200 230 460 575	Control† 15 30 50 50	120	SEO2V02S	SEG2V02S	SEW12V02S	Consult Local Square D Field Office
				208	SEO2V08	SEG2V08	SEW12V08	
				240	SEO2V03	SEG2V03	SEW12V03	
				480	SEO2V06	SEG2V06	SEW12V06	
				600	SEO2V07	SEG2V07	SEW12V07	
4	135	Separate Control† 200 230 460 575	Control† 40 50 100 100	120	SFO2V02S	SFG2V02S	SFW12V02S	
				208	SFO2V08	SFG2V08	SFW12V08	
				240	SFO2V03	SFG2V03	SFW12V03	
				480	SFO2V06	SFG2V06	SFW12V06	
				600	SFO2V07	SFG2V07	SFW12V07	

† 120 Volt Polyphase starters are wired for separate control.

* Coil voltage code must be specified to order this product. Refer to standard coil voltage codes listed in selection table above or additional standard voltage codes below and insert as shown in the HOW TO ORDER block.

Coil Voltage Codes

Voltage		Code
60 Hz	50 Hz	
24▲	...	VO1
120	110	VO2
208	...	VO8
240	220	VO3
480	440	VO6
600	550	VO7
Specify	Specify	V99

▲ 24 V coils are not available on Sizes 4-7. On Sizes 00-3, where 24 V coils are available, Form S (separate control) must be specified.

How to Order:

To Order Specify:	Catalog Number			
• Class Number	Class	Type	Coil Voltage Code	Form(s)
• Type Number				
• Coil Voltage Code				
• Form(s)				
	8536	SCG1	VO2	P1

Factory Modifications (FORMS) Refer to Catalog 9999CT9701
 Application Data Pages 13-16
 Dimensions Pages 17-20
 Separate Enclosures (Class 9991) Refer to Catalog 9999CT9701
 Replacement Parts (Class 9998) Refer to Catalog 9999CT9701
 Type S Accessories (Class 9999) Refer to Catalog 9999CT9701



File E78351
CCN NLDX



File LR60905
Class 3211-04



IEC 947-4-1



Full Voltage Starters — NEMA Selection – Class 8536

2-Pole Single Phase — 600 Volts AC Maximum — 50-60 Hertz — One Thermal Unit Required

Devices require 1 thermal unit

NEMA Size	Continuous Current Ratings	Motor Volts	Max. HP	* Coil Voltage	NEMA Type 7 & 9 Hazardous Locations Class I, Groups C & D Class II, Groups E, F, & G			NEMA Type 9 Hazardous Locations Class II, Groups E, F, & G	NEMA Type 12/3R [†] Dusttight & Driptight Industrial Use Enclosure
					Bolted Type		SPIN TOP [®] Type	Type	Type
					Cast Iron [■]	Cast Aluminum			
00	9	115 230	1/3 1	120 240	USE Size 0			USE Size 0	USE Size 0
0	18	115 230	1 2	120 240	SBT1V02 SBT1V03	SBT1V02 SBT1V03	SBR1V02 SBR1V03	SBE1V02 SBE1V03	SBA1V02 SBA1V03
1	27	115 230	2 3	120 240	SCT1V02 SCT1V03	SCT1V02 SCT1V03	SCR1V02 SCR1V03	SCE1V02 SCE1V03	SCA1V02 SCA1V03
1P	36	115 230	3 5	120 240	SCT2V02 SCT2V03	SCT2V02 SCT2V03	SCR2V02 SCR2V03	SCE2V02 SCE2V03	SCA2V02 SCA2V03
2	45	115 230	3 7 1/2	120 240	SDT6V02 SDT6V03	SDT6V02 SDT6V03	SDR6V02 SDR6V03	SDE6V02 SDE6V03	SDA6V02 SDA6V03

4-Pole 2-Phase — 600 Volts AC Maximum — 50-60 Hertz — Two Thermal Units Required

NEMA Size	Continuous Current Ratings	Motor Volts	Max. HP	* Coil Voltage	NEMA Type 7 & 9 Hazardous Locations Class I, Groups C & D Class II, Groups E, F, & G			NEMA Type 9 Hazardous Locations Class II, Groups E, F, & G	NEMA Type 12 Dusttight & Driptight Industrial Use Enclosure
					Bolted Type		SPIN TOP [®] Type	Type	Type
					Cast Iron [■]	Cast Aluminum			
0	18	Separate Control† 200 3 230 3 460 5 575 5	120 208 240 480 600	SBT3V02S SBT3V08 SBT3V03 SBT3V06 SBT3V07	Consult Local Square D Field Office	SBR3V02S SBR3V08 SBR3V03 SBR3V06 SBR3V07	...	SBA3V02S SBA3V08 SBA3V03 SBA3V06 SBA3V07	
1	27	Separate Control† 200 7 1/2 230 7 1/2 460 10 575 10	120 208 240 480 600	SCT4V02S SCT4V08 SCT4V03 SCT4V06 SCT4V07	Consult Local Square D Field Office	SCR4V02S SCR4V08 SCR4V03 SCR4V06 SCR4V07	...	SCA4V02S SCA4V08 SCA4V03 SCA4V06 SCA4V07	
2	45	Separate Control† 200 10 230 15 460 25 575 25	120 208 240 480 600	SDT2V02S SDT2V08 SDT2V03 SDT2V06 SDT2V07	Consult Local Square D Field Office	SDR2V02S SDR2V08 SDR2V03 SDR2V06 SDR2V07	...	SDA2V02S SDA2V08 SDA2V03 SDA2V06 SDA2V07	
3	90	Separate Control† 200 25 230 30 460 50 575 50	120 208 240 480 600	Consult Local Square D Field Office	Consult Local Square D Field Office	SER2V02S SER2V08 SER2V03 SER2V06 SER2V07	...	SEA2V02S SEA2V08 SEA2V03 SEA2V06 SEA2V07	
4	135	Separate Control† 200 40 230 50 460 100 575 100	120 208 240 480 600	Consult Local Square D Field Office	Consult Local Square D Field Office	SFA2V02S SFA2V08 SFA2V03 SFA2V06 SFA2V07	

† 120 Volt Polyphase contactors are wired for separate control.

◆ For NEMA Type 3R enclosed devices (2-Pole only), change 'A' in Type designation to 'H', no additional charge.

♦ Limited to one Pilot Light and Selector Switch or Start-Stop Push Button.

* Coil voltage code must be specified to order this product. Refer to standard coil voltage codes listed in selection table above or additional standard voltage codes below and insert as shown in the HOW TO ORDER block.

Coil Voltage Codes

Voltage		Code
60 Hz	50 Hz	
24 [▲]	...	VO1
120	110	VO2
208	...	VO8
240	220	VO3
480	440	VO6
600	550	VO7
Specify	Specify	V99

▲ 24 V coils are not available on Sizes 4-7. On Sizes 00-3, where 24 V coils are available, Form S (separate control) must be specified.

How to Order:

To Order Specify:	Catalog Number			
<ul style="list-style-type: none"> • Class Number • Type Number • Coil Voltage Code • Form(s) 	Class	Type	Coil Voltage Code	Form(s)
	8536	SCA1	VO3	P1

Factory Modifications (FORMS)..... Refer to Catalog 9999CT9701
 Application Data..... Pages 13-16
 Dimensions..... Pages 17-20
 Separate Enclosures (Class 9991)..... Refer to Catalog 9999CT9701
 Replacement Parts (Class 9998)..... Refer to Catalog 9999CT9701
 Type S Accessories (Class 9999)..... Refer to Catalog 9999CT9701



Full Voltage Starters Selection – Class 8536



Types SB-SD with Auxiliary Load Terminals – Class 8536 3-Pole Polyphase — Three Thermal Units Required

It is sometimes desirable to use the capacitors in motor branch circuits to improve power factor. The Size 0-2 Type SB-SD starters listed included three auxiliary terminals to allow easy connection of power factor correction capacitors. When capacitors are connected using these terminals, no adjustment on the selection of thermal units is necessary.

These terminals are also available as a kit Class 9999 Type PFL for Type S NEMA Size 0, 1 and 2 Starters with Motor Logic overload relays. These terminals are available for connection of power factor (PF) correction capacitors. These kits are sold separately and are not factory installed.

NEMA Size	Motor Volts	Maximum HP	Coil Voltage	Open Type
0	Separate Control		120	SBTO2V02S
	200	3	208	SBTO2V08
	230	3	240	SBTO2V03
	460	5	480	SBTO2V06
	575	5	600	SBTO2V07
1	Separate Control		120	SBTO3V02S
	200	7½	208	SBTO3V08
	230	7½	240	SBTO3V03
	460	10	480	SBTO3V06
	575	10	600	SBTO3V07
2	Separate Control		120	SDTO1V02S
	200	10	208	SDTO1V08
	230	15	240	SDTO1V03
	460	25	480	SDTO1V06
	575	25	600	SDTO1V07

† 120 Volt polyphase starters are wired for separate control.

Extra Capacity Single Phase Starters 2-Pole Single Phase — 250 Volts AC Maximum — 50-60 Hertz Thermal Units — Devices require 1 thermal unit. Standard trip.

Motor Volts	Max. HP	* Coil Voltage	Open Type	NEMA Type 1 General Purpose Enclosure	NEMA Type 3R Rainproof, Sleet Resistant, Outdoor Use Enclosure	NEMA Type 4 & 4X Watertight, Dusttight Brushed Stainless Steel Enclosure (Sizes 0-5)	NEMA Type 4X Watertight Corrosion Resistant Class-Polyester Enclosure	NEMA Type 12 Dusttight & Driptight Industrial Use Enclosure
				Type	Type	Type	Type	Type
115 230	5 10	120 240	SDO8V02 SDO8V03	...	SDH8V02 SDH8V03
115 230	7½ 15	120 240	SEO6V02 SEO6V03	SEG6V02 SEG6V03	SEH6V02 SEH6V03	SEW16V02 SEW16V03	SEW26V02 SEW26V03	SEA6V02 SEA6V03

* Coil voltage code must be specified to order this product. Refer to standard coil voltage codes listed in selection tables above or additional standard voltage codes below and insert as shown in the HOW TO ORDER block.

Coil Voltage Codes

Voltage		Code
60 Hz	50 Hz	
24	...	VO1
120	110	VO2
208	...	VO8
240	220	VO3
480	440	VO6
600	550	VO7
Specify	Specify	V99

How to Order:

To Order Specify:	Catalog Number			
• Class Number • Type Number • Coil Voltage Code • Form(s)	Class	Type	Coil Voltage Code	Form(s)
	8536	SEG6	VO3	P1

Factory Modifications (FORMS)Refer to Catalog 9999CT9701
 Application Data Pages 13-16
 Dimensions Pages 17-20
 Separate Enclosures (Class 9991)Refer to Catalog 9999CT9701
 Replacement Parts (Class 9998)Refer to Catalog 9999CT9701
 Type S Accessories (Class 9999)Refer to Catalog 9999CT9701



Full Voltage Contactors and Starters — NEMA Application Data – Class 8502, 8536

NEMA Size	Load Volts	Maximum Horsepower Rating – Nonplugging and Nonjogging Duty		Maximum Horsepower Rating – Plugging and Jogging Duty †		Continuous Current Rating, Amperes – 600 Volt Max.	Service – Limit Current Rating, Amperes *	Tungsten and Infrared Lamp Load, Amperes – 250 Volts Max. ★	Resistance Heating Loads, KW – Other Than Infrared Lamp Loads ‡		KVA Rating for Switching Transformer Primaries at 50 or 60 Cycles				3 Phase Rating for Switching Capacitors •
		Single Phase	Poly-Phase	Single Phase	Poly-Phase				Single Phase	Poly-Phase	Transformers Having Inrush Currents (Worst Case Peak) of Not More Than 20 Times Peak of Continuous Current Rating		Transformers Having Inrush Currents (Worst Case Peak) of Over 20 Through 40 Times Peak of Continuous Current Rating		
											Single Phase	Poly-Phase	Single Phase	Poly-Phase	Single Phase
00	115	1/2	9	11	5
	200	...	1 1/2	9	11	5
	230	1	9	11	5
	380	...	1 1/2	9	11
	460	...	2	9	11
575	...	2	9	11	
0	115	1	...	1/2	...	18	21	10	0.6	1.8	0.3	0.9	...
	200	...	3	...	1 1/2	18	21	10	1.2	2.1	0.6	1.0	...
	230	2	...	1	...	18	21	10	2.4	4.2	1.2	2.1	...
	380	...	3	...	1 1/2	18	21	3.0	5.2	1.5	2.6	...
	460	...	5	...	2	...	18	21
575	...	5	...	2	...	18	21	
1	115	2	...	1	...	27	32	15	3	5	1.2	...	0.6
	200	...	7 1/2	...	3	27	32	15	...	9.1	3.6	...	1.8
	230	3	...	2	...	27	32	15	6	10	2.4	4.3	1.2	2.1	...
	380	...	7 1/2	...	3	27	32	16.5
	460	...	10	...	5	27	32	20	4.9	8.5	2.5	4.3	...
575	...	10	...	5	27	32	25	6.2	11.0	3.1	5.3	...	
1P	115	3	...	1 1/2	...	36	42	24
	230	5	...	3	...	36	42	24
2	115	3	...	2	...	45	52	30	5	8.5	2.1	...	1.0
	200	...	10	...	7 1/2	45	52	30	...	15.4	...	6.3	...	3.1	...
	230	7 1/2	...	5	...	45	52	30	10	17	4.1	7.2	2.1	3.6	8
	380	...	25	...	15	45	52	28
	460	...	25	...	15	45	52	...	20	34	8.3	14	4.2	7.2	16
575	...	25	...	15	45	52	...	25	43	10.0	18	5.2	8.9	20	
3	115	90	104	60	10	17	4.1	...	2.0
	200	...	25	...	15	90	104	60	...	31	...	12	...	6.1	...
	230	...	30	...	20	90	104	60	20	34	8.1	14	4.1	7.0	27
	380	...	50	...	30	90	104	56
	460	...	50	...	30	90	104	...	40	68	16	28	8.1	14	53
575	...	50	...	30	90	104	...	50	86	20	35	10	18	67	
4	200	...	40	...	25	135	156	120	...	45	...	20	...	10	...
	230	...	50	...	30	135	156	120	30	52	14	23	6.8	12	40
	380	...	75	...	50	135	156	86.7
	460	...	100	...	60	135	156	...	60	105	27	47	14	23	80
	575	...	100	...	60	135	156	...	75	130	34	59	17	29	100
5	200	...	75	...	60	270	311	240	...	91	...	41	...	20	...
	230	...	100	...	75	270	311	240	...	105	27	47	14	24	80
	380	...	150	...	125	270	311	173
	460	...	200	...	150	270	311	...	120	210	54	94	27	47	160
	575	...	200	...	150	270	311	...	150	260	68	117	34	59	200
6♦	200	...	150	...	125	540	621	480	...	182	...	81	...	41	...
	230	...	200	...	150	540	621	480	...	210	...	94	...	47	...
	380	...	300	...	250	540	621	...	120	342	54	...	27	47	160
	460	...	400	...	300	540	621	415	108	188	54	94	320
	575	...	400	...	300	540	621	...	300	515	135	234	68	117	400
7♦	230	...	300	810	932	...	180	315	240
	460	...	600	810	932	625	480
	575	...	600	810	932	...	450	775	600

Tables and footnotes are taken from NEMA Standards.

† Ratings shown are for applications requiring repeated interruptions of stalled motor current or repeated closing of high transient currents encountered in rapid motor reversal, involving more than five openings or closings per minute and more than ten in a ten-minute period, such as plug-stop, plug-reverse or jogging duty. Ratings apply to single speed and multi-speed controllers.

* Per NEMA Standards paragraph ICS 2-321.20, the service-limit current represents the maximum rms current, in amperes, which the controller may be expected to carry for protracted periods in normal service. At service-limit current ratings, temperature rises may exceed those obtained by testing the controller at its continuous current rating. The ultimate trip current of over-current (overload) relays or other motor protective devices shall not exceed the service-limit current ratings of the controller.

★ FLUORESCENT LAMP LOADS – 300 VOLTS AND LESS – The characteristics of fluorescent lamps are such that it is not necessary to derate Class 8502 contactors below their normal continuous current rating. Class 8903 contactors may also be used with fluorescent lamp loads. For controlling tungsten and infrared lamp loads, and resistance heating loads, Class 8903 ac lighting contactors are recommended. These contactors are specifically designed for such loads and are applied at their full rating as listed in the Class 8903 Section.

‡ Ratings apply to contactors which are employed to switch the load at the utilization voltage of the heat producing element with a duty which requires continuous operation of not more than five openings per minute. Class 8903 Types L and S lighting contactors are rated for resistance heating loads.

• When discharged, a capacitor has essentially zero impedance. For repetitive switching by contactor, sufficient impedance should be connected in series to limit inrush current to not more than 6 times the contactor rated continuous current. In many installations, the impedance of connecting conductors may be sufficient for this purpose. When switching to connect additional banks, the banks already on the line may be charged and can supply additional available short-circuit current which should be considered when selecting the impedance to limit the current. The ratings for capacitor switching above assume the following maximum available fault currents: NEMA Size 2-3: 5,000 A RMS Sym.; NEMA Size 4-5: 10,000 A RMS Sym.; NEMA Size 6-7: 18,000 A RMS Sym. If available fault current is greater than these values, connect sufficient impedance in series as noted in the previous paragraph.

♦ See Page 16 regarding operation rates for Size 6 & 7.

The motor ratings in the above table are NEMA standard ratings and apply only when the code letter of the motor is the same as or occurs earlier in the alphabet than is shown in the table below. Motors having code letters occurring later in the alphabet may require a larger controller. Consult local Square D field office.

Motor HP Rating	Maximum Allowable Motor Code Letter
1 1/2-2	L
3-5	K
7 1/2 & above	H



Full Voltage Contactors and Starters — NEMA Application Data – Class 8502, 8536

CLASS 8502 AND 8536 APPLICATION DATA

Power Contact Ratings

All contactors and starters are rated in accordance with NEMA standards. The ratings shown in the price tables are for normal service. For complete data on power contact ratings, refer to Page 13.

Short Circuit Protection

According to the National Electrical Code branch circuit overcurrent protection must be provided for each contactor or starter. For starters refer to instructions furnished with the thermal unit selection table. For contactors (Class 8502 or 8702) provide branch circuit overcurrent protection in accordance with the National Electrical Code, except do not exceed the maximum protective device ratings in table below.

NEMA Size	Maximum Voltage	Class K5, RK5 or RK1 Fuse (Ampere)	Class J or T Fuse (Ampere)	Inverse-Time Circuit Breaker (Ampere)
00	600 250	10 12	15	15
0	600 250	20 25	30	20 35
1	600 250	30 40	60	40 60
2	600 250	60	100	80 90
3	600 250	100 125	200	125 150
4	600	200	400	225
5	600	400	600	400
6	600	600	1200*	800
7	600	600	1600*	1200

* Class L Fuse only.

Capacitor Switching

The kilovar ratings of enclosed, three phase contactors used as switches for capacitor loads, when only one load appears on the secondary of a distribution system are shown in the table on Page 13.

Coil Burden▲

NEMA Size	No. of Poles	Inrush VA		Sealed VA		Sealed Watts	
		50 Hertz	60 Hertz	50 Hertz	60 Hertz	50 Hertz	60 Hertz
00	2-3	...	165	...	33	...	6
0 & 1	1-5	232	245	26	27	7.7	7.8
2	2 & 3	296	311	36	37	12	14
	4 & 5	429	438	37	38		
3	2-3	676	700	47	46	15	14
	4-5	1260	1185	89	85	23.4	22
4	2-5	...	973	...	81	...	25
5	2-3	2970	2970	250	212	42	39
6★	2-3	1495	1780	56	48	27	32
7★	2-3	...	1960	...	59	...	36

▲ Mean values.

★ Size 6 and 7 have a DC coil. The values shown are for the AC input to the DC power supply that provides power to the coil.

Maintenance of Equipment

Class 9998 Repair Parts Kits are available for all Class 8502 contactors and Class 8536 starters. Service bulletins with a complete list of replaceable parts are supplied with all enclosed devices. Separate bulletins can be ordered and are listed along with the appropriate contact parts kit.

NEMA Type	Device Type	Series	No. of Poles	Service Bulletin	Replacement Contacts Class 9998 Type
		B	2-3	556AS	SJ1
0	SB	A & B	1-3 4 5	277AS 277AS & 250AS 277AS & 250AS	SL2 SL12 (1)SL12 & (1)SL22 or (1)SL2 & (2)SL22
1	SC	A & B	1-3 4 5	278AS 278AS & 250AS 278AS & 250AS	SL3 SL13 (1)SL13 & (1)SL22 or (1)SL3 & (2)SL22
1P	SC	A	2	278AS	SL3
2	SD	A	2-3	279AS	SL4 SL14
			4 5	279AS & 293AS 279AS & 293AS	(1)SL14 & (1)SL24 or (1)SL4 & (2)SL24
3	SE	A	2	305AS	SL6
			3 4 5	305AS 326AS 326AS	SL7 (2)SL6 (1)SL6 & (1)SL7
4	SF	A	2	306AS	SL8
			3 4 5	306AS 326AS 326AS	SL9 (2)SL8 (1)SL8 & (1)SL9
5	SG	A	2 3	328AS 328AS	SL10 SL11
6	SH	A	2	342AS	SL25
			3	342AS	SL26
6	SH	B	2	370AS	SL25
			3	370AS	SL26
7	SJ	A	2	397AS	SL30
			3	397AS	SL31

Terminals

NEMA Size	Type	Power Terminals		Control Terminals	
		Type of Lug	Wire Sizes* Min.-Max.	Type of Lug	Wire Sizes* Min.-Max.
00, 0 & 1	SA, SB & SC	Pressure Wire	#14-#8	Pressure Wire	#16-#12
2	SD	Box Lug	#14-#4	Pressure Wire	#16-#12
3	SE	Box Lug	#14-1/0	Pressure Wire	#16-#12
4	SF	Box Lug	#8-250 kcmil	Pressure Wire	#16-#12
5	SG	Box Lug	#4-500 kcmil	Pressure Wire	#16-#12
6	SH	Parallel Groove	One or two 250-500 kcmil per phase	Pressure Wire	#16-#12
7	SJ	Parallel Groove	One to four 250-500 kcmil per phase	Pressure Wire	#16-#12

* Solid or stranded copper wire.



Full Voltage Contactors and Starters — NEMA Application Data – Class 8502, 8536

Auxiliary Units

Auxiliary contacts, power poles, and timer attachments can be added by the factory or in the field on all Type S starters and contactors. The table below shows the maximum number of auxiliary units (**in addition to the holding circuit contact**) that can be added to a given size starter or contactor. In addition, it is possible to add a second internal contact on NEMA Size 0, 1, and 2 contactors and starters.

NEMA Size	Type	No. of Poles of Basic Contactor	Maximum Number of External Auxiliary Units (In addition to holding circuit contact)
00	SA	2-3	4 single circuit auxiliary contacts (N.O. or N.C.) if second internal auxiliary contact is not used.
0, 1 & 2	SB SC SD	1, 2 or 3	4 single circuit auxiliary contacts (N.O. or N.C.)
			3 single circuit auxiliary contacts (N.O. or N.C.) plus 1 attached timer (ON or OFF delay).
			2 single circuit auxiliary contacts (N.O. or N.C.) plus 1 power pole adder (1 or 2 poles, N.O. or N.C.).
		4 or 5	1 attached timer (ON or OFF delay) plus 1 power pole adder (1 or 2 poles, N.O. or N.C.) plus 1 auxiliary contact.
3, 4 & 5	SE SF SG	2-5 (Size 3 & 4)	2 single circuit auxiliary contacts (N.O. or N.C.)
		2-3 (Size 5)	2 single circuit (Sizes 3 & 4) or 3 single circuit (Size 5) auxiliary contacts plus 1 attached timer (ON or OFF delay).
			2 single circuit auxiliary contacts (N.O. or N.C.) plus 1 NEMA Size 0-1 or Size 2 power pole adder (1 or 2 poles, N.O. or N.C.)
6 & 7	SH SJ	2-3	4 single circuit auxiliary contacts (N.O. or N.C.)
			3 single circuit auxiliary contacts (N.O. or N.C.) plus 1 attached timer (ON or OFF delay).
			2 single circuit auxiliary contacts (N.O. or N.C.) plus 1 NEMA Size 0-1 or Size 2 power pole adder (1 or 2 poles, N.O. or N.C.)

Factory Installed Auxiliary Contacts

Additional auxiliary contacts may be factory or field added to any Type S contactor or starter. See table above for maximum number of auxiliary units. The table below lists the Form designations for factory installed electrical contacts.

See Class 9999 for field modification kits.

Form Number of Additional Auxiliary Contacts

When ordering factory installed auxiliary contacts, the Form designations listed should be used.

Number of N.O. Contacts	Number of N.C. Contacts	Form Number
0	1	X01
	2	X02
	3	X03
	4	X04
1	0	X10
	1	X11
	2	X12
	3	X13
2	0	X20
	1	X21
	2	X22
3	0	X30
3	1	X31
4	0	X40

Control Circuit Transformers

Class 9070 Type T machine tool control transformers are normally used when it is necessary to provide a lower voltage to the control circuit. This transformer with fused protection may be ordered from the factory by specifying Form F4T. The addition of a transformer often requires the use of a larger enclosure. The table below shows the transformer selection for given sized starters and contactors with or without auxiliary units.

NEMA Size	Type	No. of Poles	Auxiliary Units	Transformer Class 9070 Type	
0 & 1	SB SC	1-3	With max. of 2 auxiliary contacts	T50	
			With timer and maximum of 1 auxiliary contact		
			With 3 or 4 auxiliary contacts with timer and 2 or 3 auxiliary contacts	T100	
0 & 1	SB SC	4 & 5	With or without auxiliary contacts or timer	T100	
0 & 1	Mechanically Interlocked Devices	SB SC	1-5	With or without attachments	T100
2	SD	2-5	With or without attachments	T100	
3	SE	2-3	With or without attachments	GO3†	
3	SE	4 & 5	With or without attachments	T300	
4	SF	2-5	With or without attachments	T300	
5	SG	2-3	Any	T500	
6, 7	SH, SJ	2-3	Any	‡	

† Class 8502 & 8536 Type S, Size 3 standard NEMA Type 1, 4 and 12 enclosures have space for field mounting a fused control circuit transformer. A Class 9070 Type GFT3 transformer and fuse block kit is available for Form F4T requirements in a NEMA Type 1 enclosure. NEMA Type 4 and 12 enclosures utilize a Class 9070 T150 transformer and a Class 9999 SF4 fuse block.

‡ A Class 9070 transformer is an integral part of the Size 6 and Size 7 control circuit providing 120 volt control circuit voltage as standard.

Power Poles

Single or double circuit power pole adders may be factory or field installed on 2 and 3 pole Type S contactors and starters. The table below lists the Form designation for factory installed power pole adders. Only one power pole adder may be installed per contactor.

Type	NEMA Size	Class 9999 Type	Form Designation
1 N.O.	0, 1	SB6	Y428
	2	SB11	Y436
1 N.C.	0, 1	SB7	Y429
	2	SB12	Y437
1 N.O., 1 N.C.	0, 1	SB8	Y435
	2	SB13	Y440
2 N.O.	0, 1	SB9	Y430
	2	SB14	Y438
2 N.C.	0, 1	SB10	Y434
	2	SB15	Y439



Full Voltage Contactors and Starters — NEMA

Application Data – Class 8502, 8536

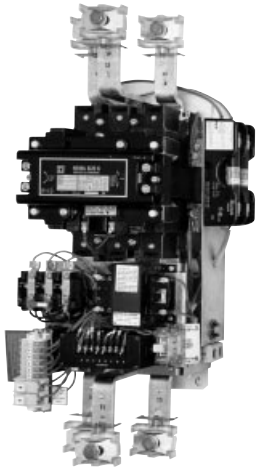

Size 6 Starter 8536 SH

Size 6 Type SH and Size 7 Type SJ Contactors and Starters

Size 6 Type SH and Size 7 Type SJ contactors and starters have a DC coil operated by a solid state rectifier circuit mounted on the device and powered from an ac source. The Size 6 and 7 are equipped as standard with a fused control circuit transformer (Form F4T) rated 240/480-120 volts 60 hertz, 220/440-110 volts 50 hertz. The purpose of this transformer is to provide an isolated 120 volts 60 hertz, 110 volts 50 hertz, supply for the control circuit. Size 6 and 7 devices may be ordered for other system voltages by specifying the voltage and frequency desired.

Operation Rates

Continuous operation rate: 3 operations/minute maximum. Jogging or Plugging Duty: 15 operations/minute – 3 minutes maximum.

Field conversion for other system voltages is accomplished by one of the following methods, **NOT BY THE USUAL PRACTICE OF CHANGING THE COIL:**

1. If the factory wiring is indicated as being for 480 volts 60 hertz, 440 volts 50 hertz, conversion to 240 volts 60 hertz, 220 volts 50 hertz, can be accomplished by reconnecting the control transformer as illustrated on instruction sheet supplied with the controller. This is the same method that would be used on Class 9070 control circuit transformers.

Conversion to any other voltage requires replacement of the control transformer. For other system voltages: i.e. 208, 277, 380, 600 volts, a new transformer with single voltage primary must be selected from table at right. Control transformer connections are illustrated on the instruction sheet supplied with the controller.

2. If the factory wiring is indicated as being for any voltage other than 480 volts 60 hertz, 440 volts 50 hertz, conversion to any other voltage requires replacement of the control transformer. Refer to table at right.
3. The standard transformer supplied may be used to power a maximum of five Class 9001 Type K illuminated operators powered with transformer type light modules. When extra capacity to power control relays or other inductive loads is required, a second transformer must be added. Extra capacity can be purchased as Form F4T with additions in 100 VA increments.

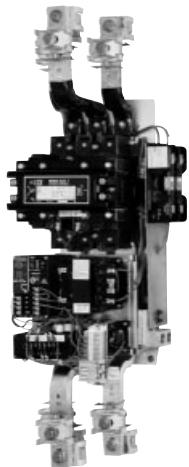

Size 7 Starter 8536 SJ

4. Standard controllers are wired for common control and are not convertible for operation of the control circuit from a separate source of supply voltage. Controllers designated Form S have special wiring designed for separate control. They are furnished with an isolating transformer, usually having a 120 volt primary and 120 volt secondary, that must not be bypassed. Form S controllers are not convertible for operation on common control.

The tables below give the replacement transformers for Type S Sizes 6 and 7 contactors and starters. To change voltages on these devices, coils are not changed, instead transformers with the desired voltage are changed.

Replacement Control Transformers for Type S Size 6

Voltage		Class 9070 Type
60 Hertz	50 Hertz	
240/480-120	220/440-110	EO3S2A
208-120	...	EO3S2B
277-120	...	EO3S2C
...	380-110	EO3S2D
600-120	550-110	EO3S2E
120-120	110-110	EO3S2F
240-120	220-110	EO3S2G

Replacement Control Transformers for Type S Size 7

Voltage		Class 9070 Type
60 Hertz	50 Hertz	
240/480-120	220/440-110	EO19S2A
208-120	...	EO19S2B
277-120	...	EO19S2C
...	380-110	EO19S2D
600-120	550-110	EO19S2E
120-120	110-110	EO19S2F
240-120	220-110	EO19S2G

Auxiliary Contacts

A N.O. holding circuit contact and a N.C. auxiliary contact are provided as standard. The holding circuit contact may or may not be required for either 3-wire or 2-wire control. Size 6 and 7 devices have an additional N.C. auxiliary contact which is wired in the coil control circuit. **DO NOT USE THIS N.C. CONTACT FOR ANY OTHER PURPOSE.**

Full Voltage Contactors and Starters — NEMA Approximate Dimensions, Shipping Weights – Class 8502, 8536

Class 8502 Open Type

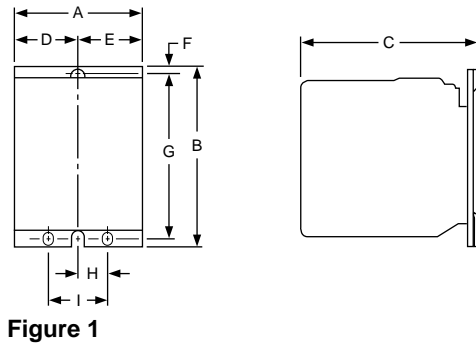

Figure 1

Class 8536 Open Type

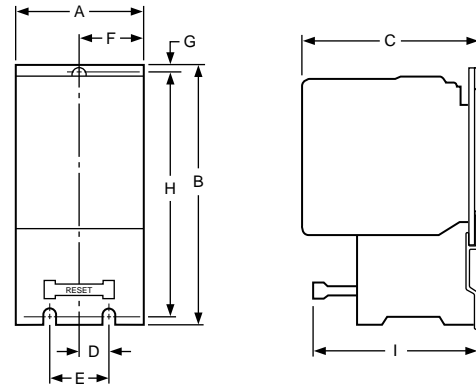

Figure 2

Class	NEMA Size	Type	No. of Poles	Fig. No.	Mtg. Screws	Dimensions – Inches/mm (Refer to Appropriate Figure)																Wt (Lbs)		
						A		B		C		D		E		F		G		H			I	
						IN	mm	IN	mm	IN	mm	IN	mm	IN	mm	IN	mm	IN	mm	IN	mm		IN	mm
8502	00	SAO	2-3	1	(2) #10	3.22	82	4.34	110	4.22	107	1.63	41	1.63	41	.22	6	3.94	100	4
	0	SBO	1-3	1	(2) #10	3.22	82	4.34	110	4.22	107	1.63	41	1.63	41	.22	6	3.94	100	4
	1	SCO	4-5			4.25	108	4.34	110	4.22	107	1.63	41	2.63	67	.22	6	3.94	100	4 1/2
	2	SDO	2-3 4-5	1	(3) #10	4.94	125	5.13	130	4.94	125	2.16	55	2.16	55	.22	6	4.59	117	.53	13	1.06	27	6 3/4
	3	SEO	2-3 4-5	1	(3) 1/4" (3) 5/16"	5.47	139	7.09	180	6.50	165	1.88	48	3.59	91	.31	8	6.03	153	3.25	83	4.75	121	14
	4	SFO	2-3 4-5	1	(3) 5/16" (3) 5/16"	6.00	152	8.19	208	6.50	165	2.06	52	3.94	100	.31	8	7.00	178	3.59	91	5.31	135	18
	5	SGO	2-3	1	(3) 1/2"	8.66	220	12.31	313	8.75	222	3.25	83	5.81	148	.63	16	11.13	283	4.75	121	7.25	184	45
	6	SHO	2-3	1	(3) 1/2"	12.34	313	28.06	713	9.00	229	3.53	90	5.78	147	5.06	129	18.56	471	4.75	121	7.25	184	80
7	SJO	2-3	1	(3) 1/2"	12.34	313	37.25	946	10.88	276	3.53	90	5.78	147	7.22	183	22.38	568	4.75	121	7.25	184	135	
8536	00, 0, 1, 1P	SAO-SCO	2-3	2	(3) #10	3.50	89	6.77	172	4.22	107	.50	13	1.00	25	1.61	41	.20	5	6.25	159	3.97	101	5
	0, 1	SBO-SCO	4	2	(3) #10	4.53	115	6.77	172	4.22	107	.50	13	1.00	25	2.66	68	.20	5	6.25	159	3.97	101	5 1/2
	2	SDO	2-3 4	2	(3) #10	4.31	109	7.81	198	4.94	125	.50	13	1.00	25	2.16	55	.20	5	7.34	186	4.06	103	7 3/4
	3	SEO	2-3 4	2	(3) 1/4" (3) 5/16"	5.47	139	11.09	282	6.50	165	.88	22	1.75	44	3.59	91	.31	8	10.19	259	5.75	146	17
	4	SFO	3 4	2	(3) 5/16" (3) 5/16"	6.00	152	12.88	327	6.50	165	1.81	46	1.75	44	3.94	100	.31	8	11.19	284	5.75	146	22
	5	SGO	3	2	(3) 1/2"	8.56	217	17.56	446	8.75	222	4.75	121	7.25	184	5.38	137	.63	16	16.38	416	6.00	152	62
	6	SHO	3	2	(3) 1/2"	12.34	313	28.06	713	9.00	229	4.75	121	7.25	184	5.78	147	5.06	129	18.56	471	8.69	221	85
	7	SJO	3	2	(3) 1/2"	12.34	313	37.25	946	10.88	276	4.75	121	7.25	184	5.78	147	7.22	183	22.38	568	9.00	229	140



Full Voltage Contactors and Starters — NEMA Approximate Dimensions, Shipping Weights – Class 8502, 8536

NEMA Type 1 — General Purpose Enclosure

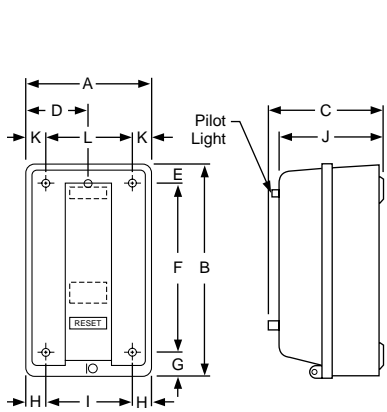

Figure 3

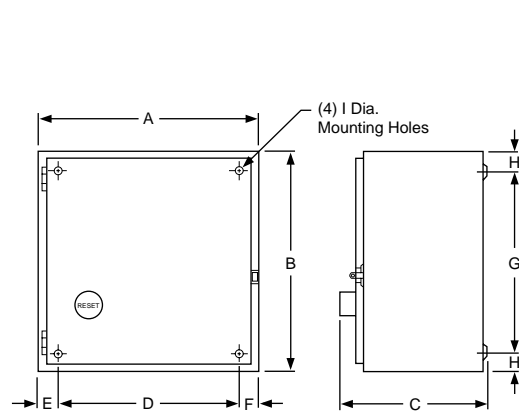

Figure 4

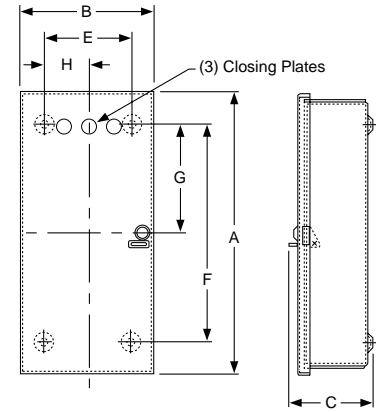

Figure 5

NEMA Size	Class	Type	No. of Poles	Fig. No.	Mtg. Screws	Dimensions – Inches/mm (Refer to Appropriate Figure)														Wt (Lbs)	
						A	B	C		D	E	F	G	H	I	J	K	L	Class 8502	Class 8536	
								8502	8536												
00	8502 & 8536	SAG	All	3	(3) #10	6.00	10.00	5.28	5.56	3.00	.88	8.13	1.00	.94	4.13	5.00	7 1/2	8	
0		152				254	134	141	76	22	207	25	24	105	127
1	8502 & 8536	SBG	All	3	(4) 1/4"	7.81	12.69	6.03	6.31	...	1.09	10.50	1.09	1.09	5.63	5.75	1.09	5.63	14 1/2	15 1/2	
1		198				322	153	160	...	28	267	28	28	143	146	28	143
2	8502 & 8536	SDG	All	3	(4) 3/8"	11.44	21.81	8.00	8.38	...	1.53	18.75	1.53	1.53	8.38	7.75	1.53	8.38	34	37	
2		291				554	203	213	...	39	476	39	39	213	197	39	213
3	8502 & 8536	SEG	All	3	(4) 3/8"	11.25	25.16	9.00	9.00	8.59	1.25	1.25	22.31	1.44	.44	52	56	
3		286				639	229	229	218	32	32	567	37	11
4	8502 & 8536	SFG	All	4	(4) 7/16"	17.22	44.22	12.81	12.94	13.00	2.13	2.13	40.00	2.13	.56	143	160	
4		437				1123	325	329	330	54	54	1016	14	14
5	8502 & 8536	SGG	All	4	(4) 9/16"	65.75	20.22	13.13	13.13	...	11.00	64.50	2.31	5.50	226	231		
5		1670				514	334	334	...	279	1638	59	140
6	8502 & 8536	SHG	All	5	(4) 1 1/16"	93.00	34.50	23.50	23.50	Floor Mounting									
6		2362				876	597	597											
7	8502 & 8536	SJG	All	5

NEMA Type 1 — General Purpose Enclosure with Form F4T

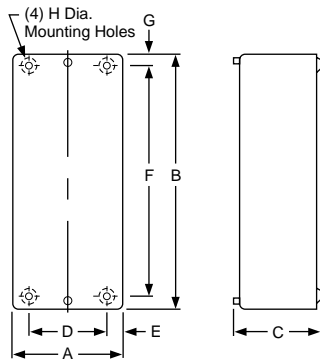

Figure 3

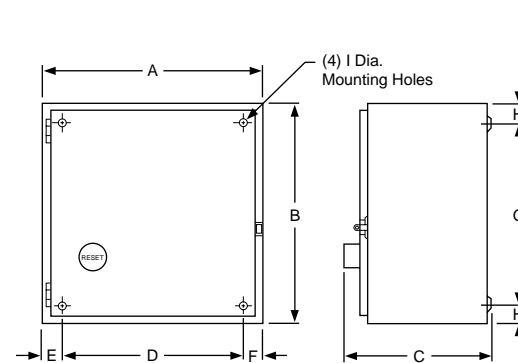

Figure 3

NEMA Size	Class	Type	No. of Poles	Fig. No.	Mtg. Screws	Dimensions – Inches/mm (Refer to Appropriate Figure)																			
						A		B		C		D	E	F	G	H	I								
						IN	mm	IN	mm	8502	8536							IN	mm	IN	mm	IN	mm	IN	mm
0	8502 & 8536	SBG	All	6	(4) 9/32	6.34	161	15.88	403	5.00	127	5.19	132	4.66	118	.84	21	14.38	365	.75	19	.28	7
1	8502 & 8536	SCG	All	6	(4) 9/32	6.34	161	15.88	403	5.00	127	5.19	132	4.66	118	.84	21	14.38	365	.75	19	.28	7
2	8502 & 8536	SDG	All	7	(4) 5/16"	14.88	378	14.13	359	7.56	192	7.66	195	12.75	324	1.06	27	1.06	27	12.00	305	1.06	27	.31	8
3	8502 & 8536	SEG	2-3	3	(4) 3/8"	Same as Standard NEMA 1 Dimensions, see above.																			
4	8502 & 8536	SFG	2-3	7	(4) 3/8"	18.16	461	29.16	741	9.25	235	9.25	235	15.50	394	1.33	34	1.33	34	26.50	673	1.33	34	.44	11
5	8502 & 8536	SGG	All	7	(4) 9/16"	Same as Standard NEMA 1 Dimensions, see above.																			
6	8502 & 8536	SHG	All	5	(4) 1 1/16"	Form F4T is supplied as standard. Refer to Page 16.																			
7	8502 & 8536	SJG	All	5	...	Form F4T is supplied as standard. Refer to Page 16.																			

Full Voltage Contactors and Starters — NEMA Approximate Dimensions, Shipping Weights – Class 8502, 8536

NEMA Type 4 & 4X — Stainless Steel Watertight Enclosures▲

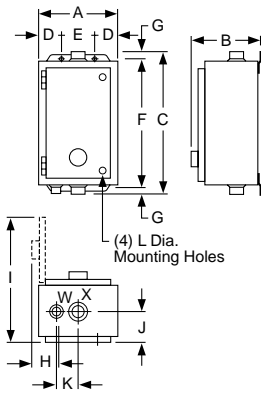

Figure 8
NEMA Type 4 & 4X
Watertight Enclosure

NEMA Size	Class	Type	No. of Poles	Dimensions – Inches/mm (Figure 8)											W. Bot. Only	X Top & Bot.	Weight (Lbs)		
				A	B	C	D	E	F	G	H	I	J	K			L	Class 8502	Class 8536
0 & 1	8502	SBW SCW	All	6.38 162	7.13 181	13.19 335	1.56 40	3.25 83	12.00 305	.59 15	1.19 30	11.78 299	1.63 41	2.31 59	.31 8	3/4" Dia. Hub	1" Dia. Hub	17	...
	8536	SBW SCW	All	6.38 162	7.81 198	13.19 335	1.56 40	3.25 83	12.00 305	.59 15	1.88 48	11.78 299	1.63 41	2.31 59	.31 8			...	18
2	8502	SDW	All	8.13 207	7.88 200	16.19 411	1.56 40	5.00 127	15.00 381	1.09 28	1.94 49	14.75 375	2.00 51	2.63 67	.31 8	3/4" Dia. Hub	1 1/2" Dia. Hub	24	...
	8536			8.13 207	8.56 217	16.19 411	1.56 40	5.00 127	15.00 381	1.09 28	2.88 73	14.75 375	2.00 51	2.63 67	.31 8			...	25
3 & 4	8502 & 8536	SEW SFW	All	18.16 461	8.75 222	32.22 818	3.08 78	12.00 305	30.50 775	.88 22	3.69 94	26.72 679	2.56 65	3.19 81	.44 11	3/4" Dia. Hub	2 1/2" Dia. Hub	65	...
		SEW SFW		All	18.16 461	9.56 243	32.22 818	3.08 78	12.00 305	30.50 775	.88 22	4.50 114	26.72 679	2.56 65	3.19 81			.44 11	...
5	8502 & 8536	SGW	All	17.22 437	12.63 321	47.22 1199	4.13 105	9.00 229	46.00 1168	.63 16	4.59 117	28.31 719	3.13 80	5.75 146	.56 14	3/4" Dia. Hub	2 1/2" Dia. Hub	159	176
6▲	8502 & 8536	SHW	All	20.22 514	12.13 308	65.22 1657	4.13 105	12.00 305	64.00 1626	.63 16	4.59 117	30.81 783	2.69 68	4.50 114	.56 14	3/4" Dia. Hub	(2) 3" Dia. Hub	227	232
7▲	8502 & 8536	SJW	All	34.50 876	23.50 597	101.00 2565	Floor Mounting										

▲ Size 6 and 7 are sheet steel enclosures and are rated NEMA Type 4 only.

NEMA Type 4 & 4X — Stainless Steel Watertight Enclosures with Form F4T▲

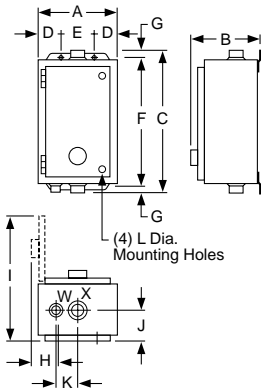

Figure 9
NEMA Type 4 & 4X
Watertight Enclosure

NEMA Size	Class	Type	No. of Poles	Dimensions – Inches/mm (Figure 9)											W Bot. Only	X Top & Bot.	
				A	B	C	D	E	F	G	H	I	J	K			L
0 & 1	8502 & 8536	SBW SCW	All	12.63 321	7.13 181	4.69 119	2.56 65	7.50 191	13.50 343	.59 15	3.19 81	18.41 468	1.66 42	2.31 59	.31 8	3/4"	1
		SBW SCW		All	12.63 321	7.81 198	14.69 373	2.56 65	7.50 191	13.50 343	.59 15	3.88 99	18.41 468	1.66 42	2.31 59		
2	8502 & 8536	SDW	All	14.88 378	7.56 192	16.31 414	2.56 65	9.75 248	15.00 381	.66 17	3.19 81	20.88 530	2.00 51	2.63 67	.31 8	3/4"	1 1/2"
				8536	14.88 378	8.25 210	16.31 414	2.56 65	9.75 248	15.00 381	.66 17	3.88 99	20.88 530	2.00 51	2.63 67		
3 & 4	8502 & 8536	SEW SFW	2-3	Same as Standard NEMA Type 4 dimensions, see above.													
3 & 4	8536	SEW SFW	2-3	See as Standard NEMA Type 4 dimensions, see above.													
5	8502 & 8536	SGW	All	Same as Standard NEMA Type 4 dimensions, see above.													
6▲	8502 & 8536	SHW	All	Form F4T is supplied as standard. Refer to Page 16.													
7▲	8502 & 8536	SJW	All	Form F4T is supplied as standard. Refer to Page 16.													

▲ Size 6 and 7 are sheet steel enclosures and are rated NEMA Type 4 only.



Full Voltage Contactors and Starters — NEMA

Approximate Dimensions, Shipping Weights – Class 8502, 8536

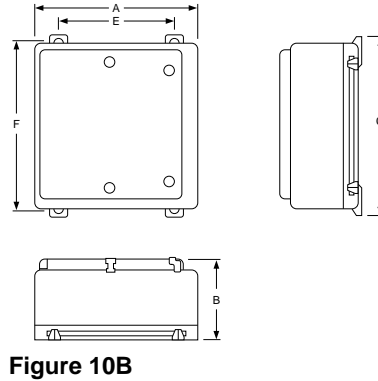
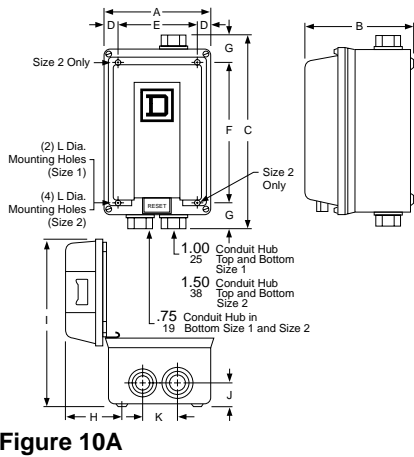

NEMA Type 4X — Watertight and Corrosion Resistant Glass Polyester Enclosures

NEMA Size	Class	Type	No. of Poles	Fig.	Dimensions — Inches/mm (Figure 11)																				Bot. Hub Only	Top & Bot. Hub	Wt (Lbs)				
					A		B		C		D		E		F		G		H		I		J					K		L	
					IN	mm	IN	mm	IN	mm	IN	mm	IN	mm	IN	mm	IN	mm	IN	mm	IN	mm	IN	mm				IN	mm	IN	mm
0, 1	8502 & 8536	SBW SCW	All	10A	6.50	165	6.44	164	12.13	308	.75	19	5.00	127	8.75	222	1.69	43	3.34	85	10.06	256	1.31	33	2.13	54	.31	8	3/4	1	17
2	8502 & 8536	SDW	All	10B	8.50	216	7.06	179	13.88	353	.75	19	7.00	179	10.50	267	1.69	43	3.91	99	11.94	303	1.63	41	2.38	60	.31	8	3/4	1 1/2	22
0-2*	8502 & 8536	SBW SCW SDW	All	10B	16.88	429	9.78	248	22.75	578	10.13	257	21.50	546
3-4†	8502 & 8536	SEW SFW	All	10B	25.81	656	11.94	303	33.50	851	18.50	470	32.25	819

* With control power transformer (Form F4T).
† Dimensions also for Form F4T.

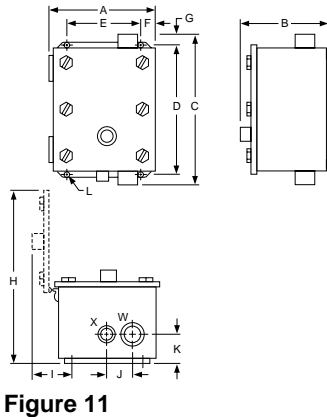

NEMA Type 9 Enclosures for Hazardous Locations — Sheet Steel

NEMA Size	Type	No. of Poles	Dimensions — Inches/mm (Figure 11)																				X Bot. Only	W Top & Bot.	Wt (Lbs)		
			A		B		C		D		E		F		G		H		I		J					K	
			IN	mm	IN	mm	IN	mm	IN	mm	IN	mm	IN	mm	IN	mm	IN	mm	IN	mm	IN	mm				IN	mm
0	SBE	2-4	8.84	225	8.22	209	13.00	330	12.00	305	6.00	152	1.38	35	.50	13	14.69	373	3.91	99	2.13	54	2.00	51	3/4"	1"	24 1/2
1	SCE	2-4	10.34	263	8.97	228	16.13	410	15.00	381	7.50	191	1.38	35	.56	14	16.94	430	3.91	99	2.75	70	2.38	60	3/4"	1 1/2"	31 1/4
2	SDE	2-4	12.84	326	9.72	247	24.16	614	22.25	565	9.00	229	1.88	48	.97	25	20.56	522	4.41	112	3.25	83	2.88	73	3/4"	2"	54
3	SEE	2-4	15.84	402	9.72	247	34.16	868	32.25	819	12.00	305	1.88	48	.97	25	23.56	598	4.41	112	3.25	83	2.88	73	3/4"	2 1/2"	74

NOTE: Devices with Form F4T may use larger enclosure. Consult local Square D Field Office for dimensions.



Full Voltage Contactors and Starters — NEMA

Approximate Dimensions, Shipping Weights – Class 8502, 8536

NEMA Type 7 & 9 Enclosures for Hazardous Locations

Sizes 0-2, Bolted Cover, Cast Iron, Sizes 0-5, Bolted Cover, Cast Aluminum, Sizes 0-5, SPIN TOP®, Cast Aluminum

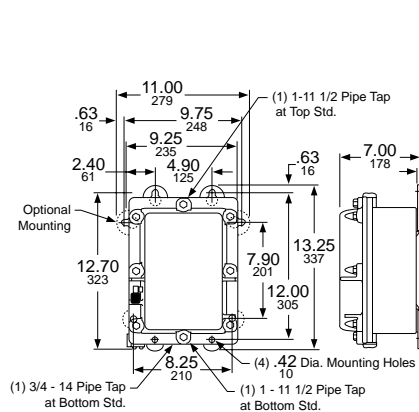

Figure 12 Size 0 and 1

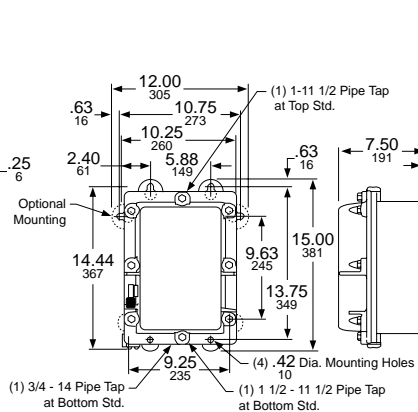

Figure 13 Size 2

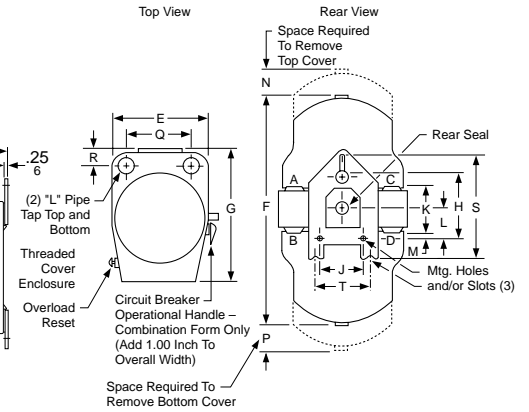

Figure 14 Size 0-5

NEMA 7 & 9 Bolted Cover, Cast Iron

NEMA Size	Type	Dimensions — Inches/mm																Wt (Lbs)
		A	B	C	D	E	F	G	H	J	K	L	M	N	P	R		
0, 1	SBT SCT	See Figure 12																59
2	SDT	See Figure 13																75

NEMA 7 & 9 SPIN TOP® Enclosure – Figure 14

NEMA Size	Type	Dimensions — Inches/mm																		Wt (Lbs)	
		A	B*	B†	C*	C†	D	E*	E†	F	G	H*	H†	J	K	L	M	N	P		R
0-1	SBR SCR	10.63	25.06	30.06	34.69	47.69	14.69	6.25	11.25	7.69	11.13	2.00	9.00	7.63	7.38	2.06	9.38	5.25	1.25	.38	70
		270	637	764	881	1211	373	159	286	195	283	51	229	194	187	52	238	133	32	10	
2	SDR	12.00	29.31	34.31	42.81	54.81	16.75	6.75	11.75	7.69	14.75	3.00	9.00	11.50	8.50	2.06	9.38	5.25	1.50	.38	100
		305	744	871	1087	1392	425	171	298	195	375	76	229	292	216	52	238	133	38	10	
3-4	SER SFR	16.13	37.50	40.50	60.00	66.50	20.25	8.63	11.63	8.63	20.25	4.50	8.00	18.00	12.00	2.63	11.00	5.50	2.50	.50	165 195
		410	953	1029	1524	1689	514	219	295	219	514	114	203	457	305	67	279	140	64	13	
5	SGR	20.75	62.13	62.13	103.63	103.63	25.75	24.13	24.13	13.88	24.13	20.00	20.00	21.50	14.38	4.75	17.00	8.00	4.00	.63	375
		527	1578	1578	2632	2632	654	613	613	353	613	508	508	546	365	121	432	203	102	16	

* Without control transformer.
† With control transformer (Form F4T)

NEMA 7 & 9 Bolted Cover, Cast Aluminum

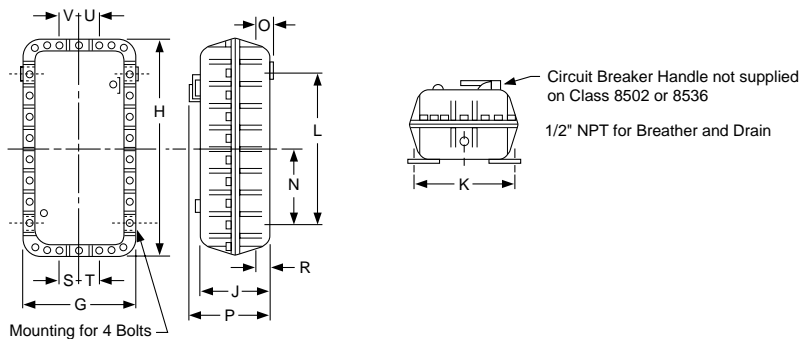

Figure 15

NEMA Size	Type	Dimensions — Inches/mm																		Wt (Lbs)
		G		H		J		K		L		N		P		Q, R		S, T, U, V		
		IN	mm	IN	mm	IN	mm	IN	mm	IN	mm	IN	mm	IN	mm	IN	mm	IN	mm	
0-1	SBT SCT	14.25	362	17.25	438	9.50	241	12.25	311	8.88	226	4.50	114	11.00	279	2.38	60	3.13	80	75
		2	SDT	13.63	346	27.63	702	9.50	241	12.25	311	19.25	489	9.63	245	11.00	279	2.38	60	
3-4	SET SFT	18.13	461	13.63	346	10.00	254	16.25	413	19.25	489	9.63	245	12.63	321	2.38	60	3.75	95	180
		5	SGT	24.50	622	45.63	1159	13.75	349	22.50	572	27.50	699	13.75	349	15.38	391	3.44	87	



Full Voltage Contactors and Starters — NEMA

Approximate Dimensions, Shipping Weights – Class 8502, 8536

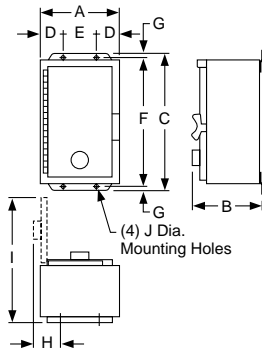

Figure 16
NEMA Type 12
Industrial Use
Enclosure

NEMA Type 12 — Dusttight Enclosure

NEMA Size	Class	Type	No. of Poles	Dimensions – Inches/mm (Figure 16)										Weight (Lbs)	
				A	B	C	D	E	F	G	H	I	J	Class 8502	Class 8536
0	8502 & 8536	SBA	All	6.38	8.53	12.75	1.56	3.25	12.00	.38	3.56	12.25	.31	15	16
1		SCA	162	217	324	40	83	305	10	90	311	8			
2	8502 & 8536	SDA	All	8.13	9.28	16.00	1.56	5.00	15.00	.50	3.56	15.38	.31	22	23
3		SEA	207	236	406	40	127	381	13	90	391	8			
4	8502 & 8536	SFA	All	18.16	9.56	31.50	3.08	12.00	30.50	.50	4.50	26.72	.44	65	68
5		SGA	461	243	800	78	305	775	13	114	679	11	69	73	
6	8502 & 8536	SHA	All	17.22	13.44	47.00	4.13	9.00	46.00	.50	5.41	28.31	.56	160	177
7		SJA	437	341	1194	105	229	1168	13	137	719	14			
6	8502 & 8536	SHA	All	20.22	13.00	65.00	4.13	12.00	64.00	.50	6.44	30.88	.69	228	233
7		SJA	514	330	1651	105	305	1626	13	164	784	18			
7	8502 & 8536	SJA	All	34.50	23.50	93.00	Floor Mounting						
				876	597	2362									

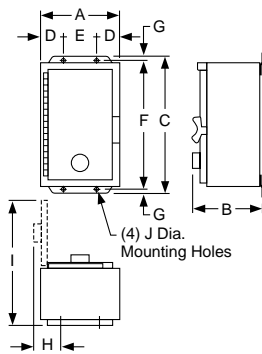

Figure 17
NEMA Type 12
Industrial Use
Enclosure

NEMA Type 12 — Dusttight Enclosure with Form F4T

NEMA Size	Class	Type	No. of Poles	Dimensions – Inches/mm (Figure 17)																			
				A		B		C		D		E		F		G		H		I		J	
				IN	mm	IN	mm	IN	mm	IN	mm	IN	mm	IN	mm	IN	mm	IN	mm	IN	mm	IN	mm
0	8502 & 8536	SBA	All	11.88	302	8.00	203	13.50	343	2.81	71	6.75	171	12.75	324	.38	10	3.91	99	18.38	467	.31	8
1		SCA	11.88	302	8.00	203	13.50	343	2.81	71	6.75	171	12.75	324	.38	10	3.91	99	18.38	467	.31	8	
2	8502 & 8536	SDA	All	14.88	378	8.13	207	16.00	406	2.56	65	9.75	248	15.00	381	.38	10	3.66	93	21.50	546	.31	8
3		SEA	14.88	378	8.13	207	16.00	406	2.56	65	9.75	248	15.00	381	.38	10	3.66	93	21.50	546	.31	8	
4	8502 & 8536	SFA	2-3	Same as Standard NEMA Type 12 dimensions, see above.																			
5		SGA	All	Same as Standard NEMA Type 12 dimensions, see above.																			
6	8502 & 8536	SHA	All	Form F4T is supplied as standard. Refer to Page 16.																			
7	8502 & 8536	SJA	All	Form F4T is supplied as standard. Refer to Page 16.																			

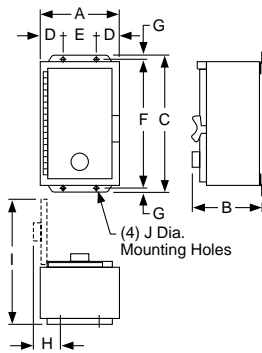

Figure 18
NEMA Type 3R
Outdoor Use
Enclosure

NEMA Type 3R — Rainproof and Sleet Resistant Enclosures

NEMA Size	Class	Type	No. of Poles	Dimensions — Inches/mm (Figure 17)																K.O. X	K.O. Y	
				A	B	C	D1	D2	E	F	G1	G2	H1	H2	J	K	L	M	N			P
0 & 1	8502 & 8536	SBH, SCH	All	8.84	12.28	7.13	1.38	1.44	6.00	7.50	2.59	2.19	2.06	2.63	14.28	1.38	1.38	1.88	4.38	1.84	1/2	1/2
				225	312	181	35	37	152	191	66	56	52	67	363	35	35	48	111	47	1	3/4
2	8502 & 8536	SDH	All	9.84	16.28	8.63	1.38	1.44	7.00	11.50	2.59	2.19	2.06	2.63	16.78	1.31	1.75	2.13	4.88	1.84	1	1/2
				250	414	219	35	37	178	292	66	56	52	67	426	33	44	54	124	47	1 1/4	3/4
3	8502 & 8536	SEH	All	12.84	25.28	8.63	1.38	1.44	10.00	20.50	2.59	2.19	2.06	2.63	19.78	1.31	1.94	2.44	6.38	1.84	1	1/2
				326	642	219	35	37	254	521	66	56	52	67	502	33	49	62	162	47	1 1/4	3/4
4	8502 & 8536	SFH	All	12.84	40.28	9.13	1.38	1.44	10.00	35.50	2.59	2.19	2.06	2.63	20.28	1.31	2.31	2.69	6.38	1.84	1	1/2
				326	1023	232	35	37	254	902	66	56	52	67	515	33	59	68	162	47	1 1/4	3/4



Full Voltage Contactors — NEMA Application Data



Class 8502 Type WF Vacuum Contactor

Electrical Ratings

Characteristic	Size 4	Size 5	Size 6
Maximum Motor HP at:			
200 V	40	75	150
230 V	50	100	200
380 V	75	150	300
460 V	100	200	400
575 V	100	200	400
3 Phase Capacitor Switching – KVAR			
230 V	40	80	160
460 V	80	160	320
575 V	100	200	400
Transformer Switching – KVA 3 Phase, 3-Pole			
240 V	23	47	94
480 V	47	94	188
600 V	59	117	234
Coil Data			
Inrush VA	300	600	1450
Sealed VA	30	20	32
Sealed Watts	6	20	30
Pick-up Volts	70% of rated coil voltage		
Drop-out Volts	50% of rated coil voltage		
Pick-up Time (ms)	18-22	24-32	24-32
Drop-out Time (ms)	90-120	96-100	96-100
Additional Electrical Characteristics			
Number of Poles	3	3	3
Max. Voltage Rating	600	600	600
Enclosed Ampere Rating	135	270	540
Max. Closing Current	1600	3000	6000
Max. Interrupting Current	1600	3000	6000
Short Time Current (RMS):			
1 second	2400	4500	9000
2 seconds	1600	3000	6000
Dielectric Strength, volts	5375	5375	5375
Max. Allowable Interrupting	1200/hr	1200/hr	1200/hr
Impulse Voltage, VA (1 x 40ms)	15000	15000	15000

General Information

Class 8502 Type W non-reversing vacuum contactors are a new addition to the Square D line of contactors. These contactors are used to switch capacitors, transformers and electric motors where overload protection is separately provided. Type W vacuum contactors are designed for operation at 600 Volts, 50/60 Hertz.

By design, these contactors are well suited to heavy-duty applications in harsh environments. The power contacts are sealed in ceramic tubes, called vacuum interrupters or vacuum bottles, where the air has been evacuated. Arc quenchers are not required because any arc formed between opening contacts is not sustained due to the presence of the vacuum. The arc is extinguished when the current crosses zero after the contacts are opened, therefore the arc typically does not survive more than one half cycle. There is one vacuum interrupter or bottle per pole, therefore a three pole contactor has three vacuum interrupters or bottles. The power contacts are not affected by ambient conditions or contamination. This provides for long life and reliable operation in harsh applications.

Altitude

The vacuum contactor is designed to tolerate normal barometric pressure variances up to 6600 feet above sea level. If the contactor is to be used above 6600 feet above sea level, please consult the factory.

Termination Means

The Size 4 vacuum contactor is supplied with line and load side lugs*. The Size 5 and 6 vacuum contactors are supplied without line and load side lugs. Class 9999 Type LUW5 and LUW6 lug kits are available for the Size 5 and 6 contactors. These kits include six lugs and the necessary mounting hardware.

Auxiliary Contacts

An auxiliary contact block, Class 9999 Type WX11, with one normally-open contact and normally-closed contact is used with the Size 4, 5 and 6 vacuum contactors.

Auxiliary Contact Units

Auxiliary contact units may be added in the field. the table below shows the maximum number of units that may be added to a given size contactor (in addition to the coil auxiliary contact).

Class 8502	
Size 4	3
Size 5	4
Size 6	4

Terminals

Size	Power Terminals Wire Size▲ Min. – Max.	Control Terminals Wire Size▲ Min. – Max.
4	#12-4/0	#16-12
5■	One #0-500 kcmil per phase	#16-12
6■	Two #0-500 kcmil per phase	#16-12

- Power terminal lugs are not supplied on Size 5 and 6 contactors. Values in table reflect those for the Size 5 and 6 lug kits, Class 9999 Type LUW5 and LUW6 respectively.
- ▲ Solid or stranded copper wire.



File E78351
CCN NLDX2



LR75167, 75168
Class 3211-04



Full Voltage Contactors — NEMA Selection – Class 8502

Class 8502 – Full Voltage Vacuum Contactors

NEMA Size	Enclosed Ampere Rating	Locked Rotor Current (Amps)	Motor Volts	Max. HP	* Coil Voltage	Open Type	NEMA Type 1 General Purpose Enclosure	NEMA Type 4 & 4X Watertight, Dusttight Brushed Stainless Steel Enclosure (Size 4 & 5 only)	NEMA Type 12 Dusttight & Driptight Industrial Use Enclosure
						Type	Type	Type	Type
4	135	1080	200	40	120	WFO3V02S	WFG3V02S	WFW3V02S	WFA3V02S
			230	50	240	WFO3V03	WFG3V03	WFW3V03	WFA3V03
			380	75	120	WFO3V02S	WFG3V002S	WFW3V02S	WFA3V02S
			460	100	480	WFO3V06	WFG3V06	WFW3V06	WFA3V06
			575	100	600	WFO3V07	WFG3V07	WFW3V07	WFA3V07
5	270	2160	200	75	120	WGO3V02S	WGG3V02S	WGW3V02S	WGA3V02S
			230	100	240	WGO3V03	WGG3V03	WGW3V03	WGA3V03
			380	150	120	WGO3V02S	WGG3V002S	WGW3V02S	WGA3V02S
			460	200	480	WGO3V06	WGG3V06	WGW3V06	WGA3V06
			575	200	600	WGO3V07	WGG3V07	WGW3V07	WGA3V07
6	540	4320	200	150	120	WHO3V02S	WHG3V02S	WHW3V02S	WHA3V02S
			230	200	240	WHO3V03	WHG3V03	WHW3V03	WHA3V03
			380	300	120	WHO3V02S	WHG3V002S	WHW3V02S	WHA3V02S
			460	400	480	WHO3V06	WHG3V06	WHW3V06	WHA3V06
			575	400	600	WHO3V07	WHG3V07	WHW3V07	WHA3V07

* Consult factory for availability of enclosed devices.

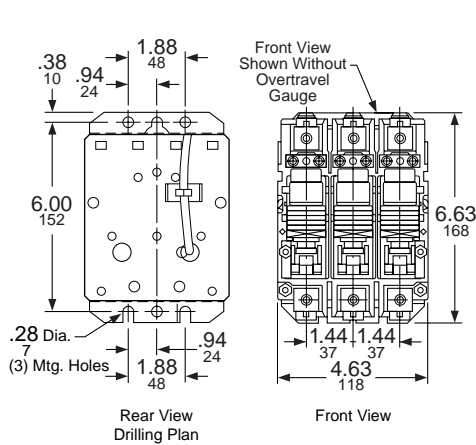

Class 8502 Type WF

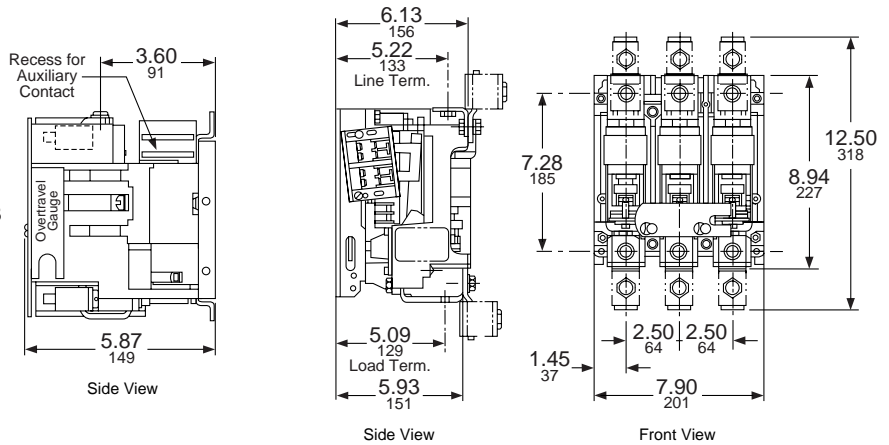

Class 8502 Type WG

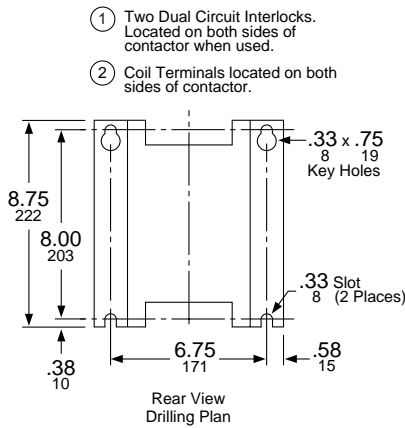

Class 8502 Type WH

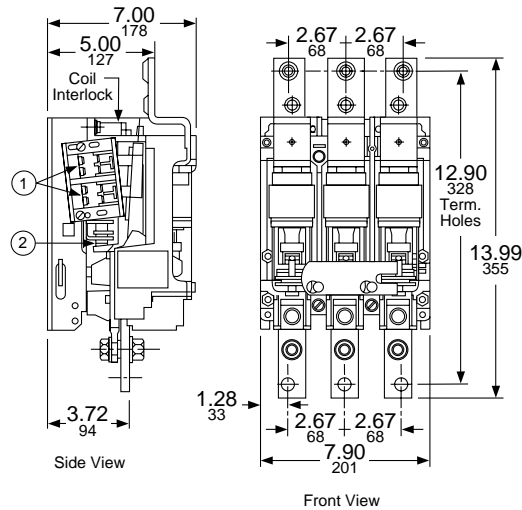

SECTION 2 – REVERSING MAGNETIC STARTERS AND CONTACTORS

Application Data – Class 8702, 8736..... 27-28
Selection – Class 8702 29-30
Selection – Class 8736 31-32
Application Data – Class 8702, 8736..... 33
Approximate Dimensions – Class 8702, 8736..... 34-36
Application Data, Selection – Class 8702 Vacuum Contactor 37
Selection – Class 8702 38





Full Voltage Reversing Contactors and Starters — NEMA Application Data – Class 8702, 8736



Size 00, 0, 1
Reversing Contactor

AC MAGNETIC REVERSING CONTACTORS CLASS 8702

General Information

Class 8702 Type S reversing magnetic contactors are used for starting, stopping, and reversing AC motors where overload protection is separately provided. Class 8702 reversing contactors are available in NEMA Sizes 00-7. Class 8702 reversing contactors consist of two Class 8502 contactors mechanically and electrically interlocked. Open type devices, Sizes 0-5 are available in either horizontal or vertical arrangements. Sizes 00, 6, and 7 are available as horizontal only. Enclosed devices, Size 00-7 use horizontally arranged components. Type S reversing contactors are designed for operation at 600 Volts AC, 50-60 Hertz.

AC MAGNETIC REVERSING STARTERS CLASS 8736

General Information

Class 8736 Type S reversing magnetic starters are used for full voltage starting, stopping, and reversing AC squirrel cage motors. Class 8736 reversing starters are available in NEMA Sizes 00-7. Class 8736 reversing starters consist of one Class 8502 contactor and one Class 8536 starter mechanically and electrically interlocked. Open type devices, Sizes 0-5 are available in either horizontal or vertical arrangements. Sizes 00, 6, and 7 are available as horizontal only. Enclosed devices use horizontally arranged components. Motor overload protection is provided by melting alloy type thermal overload relays. Type S starters are designed for operation at 600 Volts AC, 50-60 Hertz.

Overload Relays

Class 8736 Type S Size 00-6 reversing starters are provided with melting alloy thermal overload relay as standard. Interchangeable thermal units are available in standard trip Sizes 00-6, quick trip Sizes 00-4, and slow trip Sizes 00-3. Single phase starters use one thermal unit, three phase starters use three thermal units.

Class 8736 Size 7 starters are provided with solid state overload Motor Logic, which has selectable trip Class 10/20, Ground Fault Detection, and Communication capabilities for future enhancements. The solid state overload relay is

ambient insensitive and features phase loss, phase unbalance and over-current protection.

MOTOR LOGIC™ Solid State Overload Relay (SSOLR)

Solid state overload relays are available for Sizes 00-7 starters. These ambient insensitive overload relays provide phase loss protection, phase unbalance protection and LED power indicator. For additional information see the Class 9065 catalog section. To order Type S starters with solid state overload relays, see Factory Modification (FORMS).

Bimetallic overload relays are also available for Sizes 0-6. Ambient Compensated and Non-compensated versions are supplied with manual and automatic reset, trip current adjustment, and an alarm contact on Sizes 0-2. For additional information, see the Class 9065 catalog section. To order Type S starters with bimetallic overload relays, see Factory Modifications (FORMS).

Enclosures

Class 8702 and 8736 reversing magnetic contactors and starters are available in the following enclosures:

- NEMA Type 1 General Purpose Enclosure
- NEMA Type 4 & 4X Watertight and Dusttight
- NEMA Type 7 & 9 Bolted and Spin-Top for Hazardous Locations
- NEMA Type 12 Dusttight and Driptight for Industrial Use

The NEMA Type 4 and 4X stainless steel enclosure (Sizes 0-5) has a brushed finish. For an electropolished finish, specify Form G16 and add 15% to the price of the standard device. Sizes 6 and 7 are painted sheet steel and are rated NEMA Type 4 only.

Also, NEMA Type 12 devices are available UL Listed for use in Class II, Division 2, Group G and Class III, Divisions 1 and 2 locations. Request Form G21, no additional charge.

Separate enclosures are available, see Class 9991.

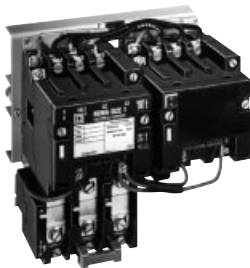

Size 00, 0, 1
Reversing Starter



Full Voltage Reversing Contactors and Starters — NEMA Application Data – Class 8702, 8736

Holding Circuit Contact

Two normally open holding circuit contacts are provided on all reversing contactors and starters as standard. Sizes 00-2 contactors use a Class 9999 SX11 auxiliary contact as the holding circuit contact. Sizes 3-7 contactors use a Class 9999 SX6 auxiliary contact as the holding circuit contact. Additionally, two normally closed auxiliary contacts are provided as standard and wired to prevent energization of both coils at the same time. Sizes 00-2 use a Class 9999 SX12 auxiliary contact while Sizes 3-7 use a Class 9999 SX7 auxiliary contact for this purpose. See Class 9999, for the holding circuit contact electrical ratings.

Coil Voltages

AC coils are available for application on 50-60 Hertz. NEMA Sizes 00-5 are supplied with coils that are designed to operate satisfactorily on line voltages of 85%-110% of rated voltage. NEMA Size 6 and 7 contactors are supplied with a DC coil operated by a solid state rectifier circuit that is powered by an AC source.

Please note that **Voltage Codes** have been added to the Type designations in order to improve customer service. It is necessary to include the Voltage Code when ordering contactors and starters. Also, 120 Volt Polyphase reversing contactors and starters will be wired for separate control.

Mechanical Interlocks

Mechanical interlocks are available for replacement or field assembly of Type S reversing contactors and starters (Sizes 00-4 ONLY). See Class 9999 for additional information.

Auxiliary Contacts

Additional auxiliary contacts may be added to Type S reversing contactors and starters. See Page 33 for maximum number of auxiliary units and Form designations for factory installed auxiliary contacts. See Class 9999 for auxiliary contact kits for field installation.

Type S Accessories

Additional accessories such as power poles, pneumatic timer attachments, and cover mounted control stations are available as factory or field modifications.



File E78351
CCN NLDX



File LR60905
Class 3211-04



Full Voltage Reversing Contactors — NEMA Selection – Class 8702

3-Pole Polyphase — 600 Volts AC Maximum — 50-60 Hertz

NEMA Size	Continuous Current Ratings	Motor Volts	Max. HP	* Coil Voltage	Open Type		NEMA Type 1 General Purpose Enclosure	NEMA Type 4 & 4X Watertight, Dusttight Brushed Stainless Steel Enclosure (Sizes 0-5)†	NEMA Type 7 & 9 Hazardous Locations Class I, Groups C & D Class II, Groups E, F & G	NEMA Type 12 Dusttight & Driptight Industrial Use Enclosure		
					Vertical Type	Horizontal Type	Type	Type	Bolted Type Aluminum	SPIN TOP® Type	Type	
00	9	Separate Control	120	200 1½	208	...	SAO4V02S	SAG4V02S	Use Size 0	Use Size 0	Use Size 0	
		230 1½		240	...	SAO4V08	SAG4V08					
		460 2		480	...	SAO4V03	SAG4V03					
		575 2		600	...	SAO4V06	SAG4V06					
		575 2		600	...	SAO4V07	SAG4V07					
0	18	Separate Control	120	200 3	208	SBO12V02S	SBO4V02S	SBG4V02S	SBW14V02S	SBT49V02S	SBR9V02S	SBA4V02S
		230 3		240	SBO12V08	SBO4V08	SBG4V08	SBW14V08	SBT49V08	SBR9V08	SBA4V08	
		460 5		480	SBO12V03	SBO4V03	SBG4V03	SBW14V03	SBT49V03	SBR9V03	SBA4V03	
		575 5		600	SBO12V06	SBO4V06	SBG4V06	SBW14V06	SBT49V06	SBR9V06	SBA4V06	
		575 5		600	SBO12V07	SBO4V07	SBG4V07	SBW14V07	SBT49V07	SBR9V07	SBA4V07	
1	27	Separate Control	120	200 7½	208	SCO7V02S	SCO8V02S	SCG8V02S	SCW14V02S	SCT49V02S	SCR9V02S	SCA4V02S
		230 7½		240	SCO7V08	SCO8V08	SCG8V08	SCW14V08	SCT49V08	SCR9V08	SCA4V08	
		460 10		480	SCO7V03	SCO8V03	SCG8V03	SCW14V03	SCT49V03	SCR9V03	SCA4V03	
		575 10		600	SCO7V06	SCO8V06	SCG8V06	SCW14V06	SCT49V06	SCR9V06	SCA4V06	
		575 10		600	SCO7V07	SCO8V07	SCG8V07	SCW14V07	SCT49V07	SCR9V07	SCA4V07	
2	45	Separate Control	120	200 10	208	SDO1V02S	SDO2V02S	SDG2V02S	SDW11V02S	SDT43V02S	SDR3V02S	SDA1V02S
		230 15		240	SDO1V08	SDO2V08	SDG2V08	SDW11V08	SDT43V08	SDR3V08	SDA1V08	
		460 25		480	SDO1V03	SDO2V03	SDG2V03	SDW11V03	SDT43V03	SDR3V03	SDA1V03	
		575 25		600	SDO1V06	SDO2V06	SDG2V06	SDW11V06	SDT43V06	SDR3V06	SDA1V06	
		575 25		600	SDO1V07	SDO2V07	SDG2V07	SDW11V07	SDT43V07	SDR3V07	SDA1V07	
3	90	Separate Control	120	200 25	208	SEO1V02S	SEO2V02S	SEG2V02S	SEW11V02S	SET43V02S	SER3V02S	SEA1V02S
		230 30		240	SEO1V08	SEO2V08	SEG2V08	SEW11V08	SET43V08	SER3V08	SEA1V08	
		460 50		480	SEO1V03	SEO2V03	SEG2V03	SEW11V03	SET43V03	SER3V03	SEA1V03	
		575 50		600	SEO1V06	SEO2V06	SEG2V06	SEW11V06	SET43V06	SER3V06	SEA1V06	
		575 540		600	SEO1V07	SEO2V07	SEG2V07	SEW11V07	SET43V07	SER3V07	SEA1V07	
4	135	Separate Control	120	200 40	208	SFO1V02S	SFO3V02S	SFG3V02S	SFW11V02S	SFA1V02S
		230 50		240	SFO1V08	SFO3V08	SFG3V08	SFW11V08	SFA1V08			
		460 100		480	SFO1V03	SFO3V03	SFG3V03	SFW11V03	SFA1V03			
		575 100		600	SFO1V06	SFO3V06	SFG3V06	SFW11V06	SFA1V06			
		575 100		600	SFO1V07	SFO3V07	SFG3V07	SFW11V07	SFA1V07			
5	270	Separate Control	120	200 75	208	SGO1V02S	SGO3V02S	SGG3V02S	SGW11V02S	SGA1V02S
		230 100		240	SGO1V08	SGO3V08	SGG3V08	SGW11V08	SGA1V08			
		460 200		480	SGO1V03	SGO3V03	SGG3V03	SGW11V03	SGA1V03			
		575 200		600	SGO1V06	SGO3V06	SGG3V06	SGW11V06	SGA1V06			
		575 200		600	SGO1V07	SGO3V07	SGG3V07	SGW11V07	SGA1V07			
6	540	Separate Control	120	200 150	208	SHO1V02S	SHG1V02S	SHW1V02S	SHW1V02S	SHA1V02S
		230 200		240	SHO1V08	SHG1V08	SHW1V08	SHW1V08	SHA1V08			
		460 400		480	SHO1V03	SHG1V03	SHW1V03	SHW1V03	SHA1V03			
		575 400		600	SHO1V06	SHG1V06	SHW1V06	SHW1V06	SHA1V06			
		575 400		600	SHO1V07	SHG1V07	SHW1V07	SHW1V07	SHA1V07			
7	810	Separate Control	120	200 —	208	SJO1V02S	SJG1V02S	SJW1V02S	SJW1V02S	SJA1V02S
		230 300		240	SJO1V08	SJG1V08	SJW1V08	SJW1V08	SJA1V08			
		460 600		480	SJO1V03	SJG1V03	SJW1V03	SJW1V03	SJA1V03			
		575 600		600	SJO1V06	SJG1V06	SJW1V06	SJW1V06	SJA1V06			
		575 600		600	SJO1V07	SJG1V07	SJW1V07	SJW1V07	SJA1V07			

◆ Size 6 and 7 are rated NEMA Type 4 only.

† 120 Volt Polyphase contactors are wired for separate control.

* Coil voltage code must be specified to order this product. Refer to standard coil voltage codes listed in selection table above or additional standard voltage codes below and insert as shown in the HOW TO ORDER block.

Coil Voltage Codes

Voltage		Code
60 Hz	50 Hz	
24▲	...	V01†▲
120	110	V02†
208	...	V08
240	220	V03
480	440	V06
600	550	V07
Specify	Specify	V99

▲ 24 V coils are not available on Sizes 4-7. On Sizes 00-3, where 24 V coils are available, Form S (separate control) must be specified.

† These voltage codes must include Form S (supplied at N.C.).

How to Order:

To Order Specify:	Catalog Number			
• Class Number	Class	Type	Coil Voltage Code	Form(s)
• Type Number				
• Coil Voltage Code				
• Form(s)				
	8702	SCG8	VO2	P1S

Factory Modifications (FORMS)..... Refer to Catalog 9999CT9701
 Application Data.....Page 33, 37
 Dimensions.....Pages 34-36
 Separate Enclosures (Class 9991)..... Refer to Catalog 9999CT9701
 Replacement Parts (Class 9998)..... Refer to Catalog 9999CT9701
 Type S Accessories (Class 9999)..... Refer to Catalog 9999CT9701



Full Voltage Reversing Contactors — NEMA Selection – Class 8702

600 Volts AC Maximum — 50-60 Hertz

NEMA Size	Continuous Current Ratings	Motor Volts	Max. HP	Type of Motor	* Coil Voltage	Open Type		NEMA Type 1 General Purpose Enclosure	NEMA Type 4 & 4X Watertight, Dusttight Brushed Stainless Steel Enclosure	NEMA Type 7 & 9 Hazardous Locations Class I, Groups C & D Class II, Groups E, F & G		NEMA Type 12 Dusttight & Driptight Industrial Use Enclosure
						Vertical Type	Horizontal Type	Type	Type	Bolted Type	SPIN TOP® Type	Type
2-Pole Single Phase												
00	9	115 230	1/3 1	Single Phase 3-Wire	120 240	...	SAO1V02 SAO1V03	SAG1V02 SAG1V03	Use Size 0	Use Size 0	Use Size 0	Use Size 0
0	18	115 230	1 2		120 240	SBO9V02 SBO9V03	SBO1V02 SBO1V03	SBG1V02 SBG1V03	SBW11V02 SBW11V03	SBT46V02 SBT46V03	SBR6V02 SBR6V03	SBA1V02 SBA1V03
1	27	115 230	2 3		120 240	SCO1V02 SCO1V03	SCO2V02 SCO2V03	SCG2V02 SCG2V03	SCW11V02 SCW11V03	SCT46V02 SCT46V03	SCR6V02 SCR6V03	SCA1V02 SCA1V03
3-Pole Single Phase												
00	9	115 230	1/3 1	4-Wire Rep.-Ind.	120 240	...	SAO2V02 SAO2V03	SAG2V02 SAG2V03	Use Size 0	Use Size 0	Use Size 0	Use Size 0
		115 230	1/3 1	4-Wire Split Ph.	120 240	...	SAO3V02 SAO3V03	SAG3V02 SAG3V03	Use Size 0	Use Size 0	Use Size 0	Use Size 0
0	18	115 230	1 2	4-Wire Rep.-Ind.	120 240	SBO10V02 SBO10V03	SBO2V02 SBO2V03	SBG2V02 SBG2V03	SBW12V02 SBW12V03	SBT47V02 SBT47V03	SBR7V02 SBR7V03	SBA2V02 SBA2V03
		115 230	1 2	4-Wire Split Ph.	120 240	SBO11V02 SBO11V03	SBO3V02 SBO3V03	SBG3V02 SBG3V03	SBW13V02 SBW13V03	SBT48V02 SBT48V03	SBR8V02 SBR8V03	SBA3V02 SBA3V03
1	27	115 230	2 3	4-Wire Rep.-Ind.	120 240	SCO3V02 SCO3V03	SCO4V02 SCO4V03	SCG4V02 SCG4V03	SCW12V02 SCW12V03	SCT47V02 SCT47V03	SCR7V02 SCR7V03	SCA2V02 SCA2V03
		115 230	2 3	4-Wire Split Ph.	120 240	SCO5V02 SCO5V03	SCO6V02 SCO6V03	SCG6V02 SCG6V03	SCW13V02 SCW13V03	SCT48V02 SCT48V03	SCR8V02 SCR8V03	SCA3V02 SCA3V03
4-Pole Polyphase												
0	18	Separate Control		2 Phase 2 Wire	120 208 240 480 600	SBO13V02S SBO13V08 SBO13V03 SBO13V06 SBO13V07	SBO5V02S SBO5V08 SBO5V03 SBO5V06 SBO5V07	SBG5V02S SBG5V08 SBG5V03 SBG5V06 SBG5V07	SBW15V02S SBW15V08 SBW15V03 SBW15V06 SBW15V07	Consult Local Square D Field Office	SBR10V02S SBR10V08 SBR10V03 SBR10V06 SBR10V07	SBA5V02S SBA5V08 SBA5V03 SBA5V06 SBA5V07
		200 230 460 575	3 3 5 5		120 208 240 480 600	SCO9V02S SCO9V08 SCO9V03 SCO9V06 SCO9V07	SCO10V02S SCO10V08 SCO10V03 SCO10V06 SCO10V07	SCG10V02S SCG10V08 SCG10V03 SCG10V06 SCG10V07	SCW15V02S SCW15V08 SCW15V03 SCW15V06 SCW15V07		SCR10V02S SCR10V08 SCR10V03 SCR10V06 SCR10V07	SCA5V02S SCA5V08 SCA5V03 SCA5V06 SCA5V07
1	27	Separate Control		2 Phase 2 Wire	120 208 240 480 600	SDO4V02S SDO4V08 SDO4V03 SDO4V06 SDO4V07	SDG4V02S SDG4V08 SDG4V03 SDG4V06 SDG4V07	SDW12V02S SDW12V08 SDW12V03 SDW12V06 SDW12V07	Consult Local Square D Field Office	SDR4V02S SDR4V08 SDR4V03 SDR4V06 SDR4V07	SDA2V02S SDA2V08 SDA2V03 SDA2V06 SDA2V07	
		200 230 460 575	10 15 25 25		120 208 240 480 600	SEO4V02S SEO4V08 SEO4V03 SEO4V06 SEO4V07	SEG4V02S SEG4V08 SEG4V03 SEG4V06 SEG4V07	SEW12V02S SEW12V08 SEW12V03 SEW12V06 SEW12V07		SEA2V02S SEA2V08 SEA2V03 SEA2V06 SEA2V07		
3	90	Separate Control		2 Phase 2 Wire	120 208 240 480 600	SFO4V02S SFO4V08 SFO4V03 SFO4V06 SFO4V07	SFG4V02S SFG4V08 SFG4V03 SFG4V06 SFG4V07	SFW12V02S SFW12V08 SFW12V03 SFW12V06 SFW12V07	...	SFA2V02S SFA2V08 SFA2V03 SFA2V06 SFA2V07		
		200 230 460 575	25 30 50 50		120 208 240 480 600	SFO4V02S SFO4V08 SFO4V03 SFO4V06 SFO4V07	SFG4V02S SFG4V08 SFG4V03 SFG4V06 SFG4V07	SFW12V02S SFW12V08 SFW12V03 SFW12V06 SFW12V07		SFA2V02S SFA2V08 SFA2V03 SFA2V06 SFA2V07		
4	135	Separate Control		2 Phase 2 Wire	120 208 240 480 600	SFO4V02S SFO4V08 SFO4V03 SFO4V06 SFO4V07	SFG4V02S SFG4V08 SFG4V03 SFG4V06 SFG4V07	SFW12V02S SFW12V08 SFW12V03 SFW12V06 SFW12V07	...	SFA2V02S SFA2V08 SFA2V03 SFA2V06 SFA2V07		
		200 230 460 575	40 50 100 100		120 208 240 480 600	SFO4V02S SFO4V08 SFO4V03 SFO4V06 SFO4V07	SFG4V02S SFG4V08 SFG4V03 SFG4V06 SFG4V07	SFW12V02S SFW12V08 SFW12V03 SFW12V06 SFW12V07		SFA2V02S SFA2V08 SFA2V03 SFA2V06 SFA2V07		

* Coil voltage code must be specified to order this product. Refer to standard coil voltage codes listed in selection table above or additional standard voltage codes below and insert as shown in the HOW TO ORDER block.

Coil Voltage Codes

Voltage		Code
60 Hz	50 Hz	
24▲	...	V01†
120	110	V02†
208	...	V08
240	220	V03
480	440	V06
600	550	V07
Specify	Specify	V99

▲ 24 V coils are not available on Sizes 4-7. On Sizes 00-3, where 24 V coils are available, Form S (separate control) must be specified.

† These voltage codes must include Form S (supplied at N.C.).



File E78351
CCN NLDX



File LR60905
Class 3211-04

How to Order:

To Order Specify:	Catalog Number			
<ul style="list-style-type: none"> Class Number Type Number Coil Voltage Code Form(s) 	Class	Type	Coil Voltage Code	Form(s)
	8702	SCG2	VO2	P1S

Factory Modifications (FORMS) Refer to Catalog 9999CT9701
 Application Data Page 33, 37
 Dimensions Pages 34-36
 Separate Enclosures (Class 9991) Refer to Catalog 9999CT9701
 Replacement Parts (Class 9998) Refer to Catalog 9999CT9701
 Type S Accessories (Class 9999) Refer to Catalog 9999CT9701



Full Voltage Reversing Starters — NEMA Selection – Class 8736

3-Pole Polyphase—Three Thermal Units Required

NEMA Size	Continuous Current Ratings	Motor Volts	Max. HP	* Coil Voltage	Open Type		NEMA Type 1 General Purpose Enclosure	NEMA Type 4 & 4X Watertight, Dusttight Brushed Stainless Steel Enclosure (Size 0-5)†	NEMA Type 7 & 9 Hazardous Locations Class I, Groups C & D Class II, Groups E, F & G		NEMA Type 12 Dusttight & Driptight Industrial Use Enclosure
					Vertical Type	Horizontal Type	Type	Type	Bolted Type	SPIN TOP® Type	Type
00	9	Separate Control†	1 1/2	120	...	SAO16V02S	SAG16V02S	Use Size 0	Use Size 0	Use Size 0	Use Size 0
		200		SAO16V08		SAG16V08					
		230		SAO16V03		SAG16V03					
		460		SAO16V06		SAG16V06					
		575		SAO16V07		SAG16V07					
0	18	Separate Control†	3	120	...	SBO10V02S	SBG4V02S	Use Size 0	Use Size 0	Use Size 0	Use Size 0
		200		SBO10V08		SBG4V08					
		230		SBO10V03		SBG4V03					
		460		SBO10V06		SBG4V06					
		575		SBO10V07		SBG4V07					
1	27	Separate Control†	7 1/2	120	...	SCO7V02S	SCG8V02S	Use Size 0	Use Size 0	Use Size 0	Use Size 0
		200		SCO7V08		SCG8V08					
		230		SCO7V03		SCG8V03					
		460		SCO7V06		SCG8V06					
		575		SCO7V07		SCG8V07					
2	45	Separate Control†	10	120	...	SDO1V02S	SDG2V02S	Use Size 0	Use Size 0	Use Size 0	Use Size 0
		200		SDO1V08		SDG2V08					
		230		SDO1V03		SDG2V03					
		460		SDO1V06		SDG2V06					
		575		SDO1V07		SDG2V07					
3	90	Separate Control†	25	120	...	SEO1V02S	SEG2V02S	Use Size 0	Use Size 0	Use Size 0	Use Size 0
		200		SEO1V08		SEG2V08					
		230		SEO1V03		SEG2V03					
		460		SEO1V06		SEG2V06					
		575		SEO1V07		SEG2V07					
4	135	Separate Control†	40	120	...	SFO1V02S	SFG3V02S	Use Size 0	Use Size 0	Use Size 0	Use Size 0
		200		SFO1V08		SFG3V08					
		230		SFO1V03		SFG3V03					
		460		SFO1V06		SFG3V06					
		575		SFO1V07		SFG3V07					
5	270	Separate Control†	75	120	...	SGO1V02S	SGG3V02S	Use Size 0	Use Size 0	Use Size 0	Use Size 0
		200		SGO1V08		SGG3V08					
		230		SGO1V03		SGG3V03					
		460		SGO1V06		SGG3V06					
		575		SGO1V07		SGG3V07					
6	540	Separate Control†	150	120	...	SHO1V02S	SHG1V02S	Use Size 0	Use Size 0	Use Size 0	Use Size 0
		200		SHO1V08		SHG1V08					
		230		SHO1V03		SHG1V03					
		460		SHO1V06		SHG1V06					
		575		SHO1V07		SHG1V07					
7	810	Separate Control†	300	120	...	SJO1V02S	SJG1V02S	Use Size 0	Use Size 0	Use Size 0	Use Size 0
		200		SJO1V08		SJG1V08					
		230		SJO1V03		SJG1V03					
		460		SJO1V06		SJG1V06					
		575		SJO1V07		SJG1V07					

♦ Size 6 and 7 are sheet steel rated NEMA Type 4 only.

† 120 Volt Polyphase starters are wired for separate control.

* Coil voltage code must be specified to order this product. Refer to standard coil voltage codes listed in selection table above or additional standard voltage codes below and insert as shown in the HOW TO ORDER block.

Coil Voltage Codes

Voltage		Code
60 Hz	50 Hz	
24▲	...	V01
120	110	V02
208	...	V08
240	220	V03
480	440	V06
600	550	V07
Specify	Specify	V99

▲ 24 V coils are not available on Sizes 4-7. On Sizes 00-3, where 24 V coils are available, Form S (separate control) must be specified.

How to Order:

To Order Specify: • Class Number • Type Number • Coil Voltage Code • Form(s)	Catalog Number <table style="width: 100%; border-collapse: collapse;"> <tr> <td style="border: 1px solid black; padding: 2px;">Class</td> <td style="border: 1px solid black; padding: 2px;">Type</td> <td style="border: 1px solid black; padding: 2px;">Coil Voltage Code</td> <td style="border: 1px solid black; padding: 2px;">Form(s)</td> </tr> <tr> <td style="text-align: center; border: 1px solid black; padding: 2px;">8736</td> <td style="text-align: center; border: 1px solid black; padding: 2px;">SCG8</td> <td style="text-align: center; border: 1px solid black; padding: 2px;">VO2</td> <td style="text-align: center; border: 1px solid black; padding: 2px;">P1S</td> </tr> </table>	Class	Type	Coil Voltage Code	Form(s)	8736	SCG8	VO2	P1S
Class	Type	Coil Voltage Code	Form(s)						
8736	SCG8	VO2	P1S						

Factory Modifications (FORMS)..... Refer to Catalog 9999CT9701
Application Data..... Page 33, 37
Dimensions..... Pages 34-36
Separate Enclosures (Class 9991)..... Refer to Catalog 9999CT9701
Replacement Parts (Class 9998)..... Refer to Catalog 9999CT9701
Type S Accessories (Class 9999)..... Refer to Catalog 9999CT9701



Full Voltage Reversing Starters — NEMA Selection – Class 8736

600 Volts AC Maximum — 50-60 Hertz

NEMA Size	Continuous Current Ratings	Motor Volts	Max. HP	Type of Motor	* Coil Voltage	Open Type		NEMA Type 1 General Purpose Enclosure	NEMA Type 4 & 4X Watertight, Dusttight Brushed Stainless Steel Enclosure	NEMA Type 7 & 9 Hazardous Locations Class I, Groups C & D Class II, Groups E, F & G		NEMA Type 12 Dusttight & Driptight Industrial Use Enclosure
						Vertical Type	Horizontal Type	Type	Type	Bolted Type	SPIN TOP® Type	Type
2-Pole Single Phase — 1 Thermal Unit Required												
00	9	115 230	1/3 1	Single Phase 3-Wire	120 240	...	SAO13V02 SAO13V08	SAG13V02 SAG13V08	Use Size 0	Use Size 0	Use Size 0	Use Size 0
0	18	115 230	1 2		120 240	SBO7V02 SBO7V08	SBO1V02 SBO1V08	SBG1V02 SBG1V08	SBW11V02 SBW11V08	SBT46V02 SBT46V08	SBR6V02 SBR6V08	SBA1V02 SBA1V08
1	27	115 230	2 3		120 240	SCO1V02 SCO1V08	SCO2V02 SCO2V08	SCG2V02 SCG2V08	SCW11V02 SCW11V08	SCT46V02 SCT46V08	SCR6V02 SCR6V08	SCA1V02 SCA1V08
3-Pole Single Phase — 1 Thermal Unit Required												
00	9	115 230	1/3 1	4-Wire Rep.-Ind.	120 240	...	SAO14V02 SAO14V08	SAG14V02 SAG14V08	Use Size 0	Use Size 0	Use Size 0	Use Size 0
		115 230	1/3 1	4-Wire Split Ph.	120 240	...	SAO15V02 SAO15V08	SAG15V02 SAG15V08	Use Size 0	Use Size 0	Use Size 0	Use Size 0
0	18	115 230	1 2	4-Wire Rep.-Ind.	120 240	SBO80V02 SBO8V08	SBO2V02 SBO2V08	SBG2V02 SBG2V08	SBW12V02 SBW12V08	SBT47V02 SBT47V08	SBR7V02 SBR7V08	SBA2V02 SBA2V08
		115 230	1 2	4-Wire Split Ph.	120 240	SBO9V02 SBO9V08	SBO3V02 SBO3V08	SBG3V02 SBG3V08	SBW13V02 SBW13V08	SBT48V02 SBT48V08	SBR8V02 SBR8V08	SBA3V02 SBA3V08
1	27	115 230	2 3	4-Wire Rep.-Ind.	120 240	SCO3V02 SCO3V08	SCO4V02 SCO4V08	SCG4V02 SCG4V08	SCW12V02 SCW12V08	SCT47V02 SCT47V08	SCR7V02 SCR7V08	SCA2V02 SCA2V08
		115 230	2 3	4-Wire Split Ph.	120 240	SCO5V02 SCO5V08	SCO6V02 SCO6V08	SCG6V02 SCG6V08	SCW13V02 SCW13V08	SCT48V02 SCT48V08	SCR8V02 SCR8V08	SCA3V02 SCA3V08
4-Pole Polyphase — 2 Thermal Units Required												
0	18	Separate Control† 200 230 460 575	3 3 5 5	2 Phase 2 Wire	120 208 240 480 600	SBO11V02S SBO11V08 SBO11V03 SBO11V06 SBO11V07	SBO5V02S SBO5V08 SBO5V03 SBO5V06 SBO5V07	SBG5V02S SBG5V08 SBG5V03 SBG5V06 SBG5V07	SBW15V02S SBW15V08 SBW15V03 SBW15V06 SBW15V07	Consult Local Square D Field Office	SBR10V02S SBR10V08 SBR10V03 SBR10V06 SBR10V07	SBA5V02S SBA5V08 SBA5V03 SBA5V06 SBA5V07
1	27	Separate Control† 200 230 460 575	7 1/2 7 1/2 10 10		120 208 240 480 600	SCO9V02S SCO9V08 SCO9V03 SCO9V06 SCO9V07	SCO10V02S SCO10V08 SCO10V03 SCO10V06 SCO10V07	SCG10V02S SCG10V08 SCG10V03 SCG10V06 SCG10V07	SCW15V02S SCW15V08 SCW15V03 SCW15V06 SCW15V07	Consult Local Square D Field Office	SCR10V02S SCR10V08 SCR10V03 SCR10V06 SCR10V07	SCA5V02S SCA5V08 SCA5V03 SCA5V06 SCA5V07
2	45	Separate Control† 200 230 460 575	10 15 25 25		120 208 240 480 600	SDO4V02S SDO4V08 SDO4V03 SDO4V06 SDO4V07	SDG4V02S SDG4V08 SDG4V03 SDG4V06 SDG4V07	SDW12V02S SDW12V08 SDW12V03 SDW12V06 SDW12V07	Consult Local Square D Field Office	SDR4V02S SDR4V08 SDR4V03 SDR4V06 SDR4V07	SDA2V02S SDA2V08 SDA2V03 SDA2V06 SDA2V07	
3	90	Separate Control† 200 230 460 575	25 30 50 50		120 208 240 480 600	SEO4V02S SEO4V08 SEO4V03 SEO4V06 SEO4V07	SEG4V02S SEG4V08 SEG4V03 SEG4V06 SEG4V07	SEW12V02S SEW12V08 SEW12V03 SEW12V06 SEW12V07	SEA2V02S SEA2V08 SEA2V03 SEA2V06 SEA2V07	
4	135	Separate Control† 200 230 460 575	40 50 100 100		120 208 240 480 600	SFO4V02S SFO4V08 SFO4V03 SFO4V06 SFO4V07	SFG4V02S SFG4V08 SFG4V03 SFG4V06 SFG4V07	SFW12V02S SFW12V08 SFW12V03 SFW12V06 SFW12V07	SFA2V02S SFA2V08 SFA2V03 SFA2V06 SFA2V07	

† 120 Volt starters are wired for separate control.

* Coil voltage code must be specified to order this product. Refer to standard coil voltage codes listed in selection table above or additional standard voltage codes below and insert as shown in the HOW TO ORDER block.

Coil Voltage Codes

Voltage		Code
60 Hz	50 Hz	
24▲	...	V01
120	110	V02
208	...	V08
240	220	V03
480	440	V06
600	550	V07
Specify	Specify	V99

▲ 24 V coils are not available on Sizes 4-7. On Sizes 00-3, where 24 V coils are available, Form S (separate control) must be specified.



File E78351
CCN NLDX



File LR60905
Class 3211-04

How to Order:

To Order Specify:	Catalog Number			
<ul style="list-style-type: none"> • Class Number • Type Number • Coil Voltage Code • Form(s) 	Class	Type	Coil Voltage Code	Form(s)
	8736	SCG8	VO2	P1S

Factory Modifications (FORMS) Refer to Catalog 9999CT9701
 Application Data Page 33, 37
 Dimensions Pages 34-36
 Separate Enclosures (Class 9991) Refer to Catalog 9999CT9701
 Replacement Parts (Class 9998) Refer to Catalog 9999CT9701
 Type S Accessories (Class 9999) Refer to Catalog 9999CT9701



Full Voltage Reversing Contactors and Starters — NEMA Application Data – Class 8702, 8736

Power Contact Ratings

All contactors are rated in accordance with NEMA standards. The ratings shown in the tables on Pages 29-32 are for normal service. For complete data on power contact ratings, refer to Class 8536 Section.

Maintenance of Equipment

Class 9998 repair parts kits are available for all Class 8702 contactors and Class 8736 starters. Service bulletins with a complete list of replaceable parts are supplied with all devices. See Page 15.

Control Transformer Selection

The following table gives the proper size control transformer to be used with a given reversing device, with or without additional auxiliary contacts or timer. For factory addition of control transformers, see Factory Modifications (Forms) section.

NEMA Size	Type	No. of Poles	Transformers Class 9070 Type
0, 1 & 2	SB, SC & SD	Any	T100 or GO2
3	SE	3	T1500 or GO3
		4 & 5	T300
4	SF	Any	T300
5	SG	Any	T500
6 & 7	SH & SJ	Any	See Page 16

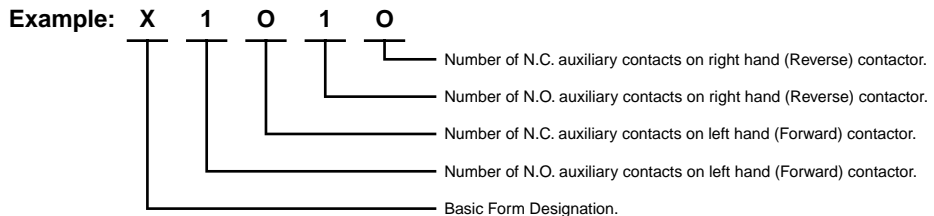

Auxiliary Units

The table below shows the maximum number of auxiliary units (**in addition to the holding circuit and interlocking contacts**) that can be added to either the forward or reverse contactor or starter.

NEMA Size (Type)	No. of Poles of Basic Contactor	Maximum number of auxiliary units on each contactor, forward or reverse, (in addition to internal holding circuit and interlocking contacts).
00 (SA)	2 or 3	2 single circuit auxiliary contacts (N.O. or N.C.)
0, 1 & 2 (SB, SC & SD)	2 or 3	4 single circuit auxiliary contacts▲ (N.O. or N.C.) 1 single circuit auxiliary contact (N.O. or N.C.) plus 1 attached timer (ON or OFF delay).
	4	2 single circuit auxiliary contacts (N.O. or N.C.)
3, 4, 5, 6, & 7 (SE, SF, SG, SH, & SJ)	Any	2 single circuit auxiliary contacts (N.O. or N.C.)
		1 single circuit auxiliary contact plus 1 attached timer (ON or OFF delay).

▲ When adding 4 external auxiliary contacts to one Size 0 or 1 contactor, remove one of the return springs.

Factory Installed Auxiliary Contacts

Additional auxiliary contacts may be factory or field added to any Type 3 contactor or starter. See table above for maximum number of auxiliary units. The table below lists the Form designations for factory installed auxiliary contacts. See Class 9999 for field modification kits.

		Additional Auxiliary Contacts on R.H. Contactor (Reverse Contactor)					
		Standard (No Additional Auxiliary Contacts)	1 N.O.	1 N.C.	2 N.O.	1 N.O.-1 N.C.	2 N.C.
Additional Auxiliary Contacts on L.H. Contactor (Forward Contactor)	Standard (No Additional Auxiliary Contacts)		X0010	X0001	X0020	X0011	X0002
	1 N.O.	X1000	X1010	X1001	X1020	X1011	X1002
	1 N.C.	X0100	X0110	X0101	X0120	X0111	X0102
	2 N.O.	X2000	X2010	X2001	X2020	X2011	X2002
	1 N.O.-1 N.C.	X1100	X1110	X1101	X1120	X1111	X1102
	2 N.C.	X0200	X0210	X0201	X0220	X0211	X0202



Full Voltage Reversing Contactors and Starters — NEMA Approximate Dimensions – Class 8702, 8736

Open Type — 2 or 3-Pole Only

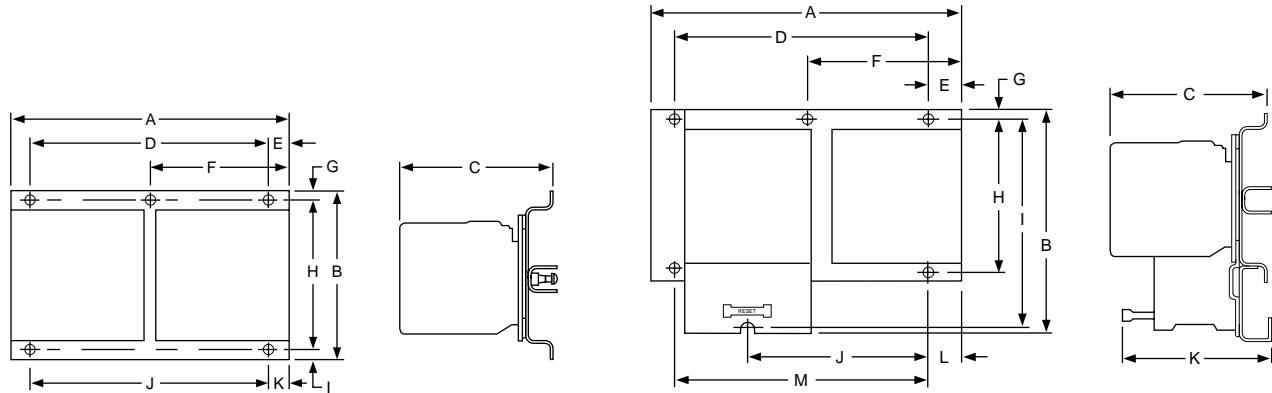

Class	NEMA Size	Type	Mounting	Figure Number	Dimensions — Inches/mm													Weight (Lbs)
					A	B	C	D	E	F	G	H	I	J	K	L	M	
8702	00	SAO	Horizontal	1	7.13 181	5.00 127	5.31 135	3.41 87	.47 12	4.34 110	.19 5	5.50 140	.91 23	12
	0	SBO	Horizontal	1	7.13 181	5.00 127	5.31 135	3.41 87	.47 12	4.34 110	.19 5	5.50 140	.91 23	12
	1	SCO	Vertical	1*	5.41 137	9.22 234	5.31 135	5.03 128	.22 661 15	8.00 203	.61 15	5.03 128	.22 6	12
	2	SDO	Horizontal	1	9.00 229	6.88 175	6.03 153	4.50 114	.38 10	5.63 143	.25 6	6.00 152	1.50 38	16
			Vertical	1*	6.75 171	11.38 289	6.03 153	6.25 159	.25 650 13	10.38 264	.50 13	6.25 159	.25 6	16
	3	SEO	Horizontal	1	12.72 323	7.97 202	7.00 178	11.75 298	.48 1248 12	7.00 178	.48 12	11.75 298	.48 12	35
			Vertical	1*	7.20 183	19.00 483	7.00 178	6.25 159	.48 12	...	1.02 26	17.00 432	.98 25	6.25 159	.48 12	35
	4	SFO	Horizontal	1	14.25 362	11.69 297	7.00 178	13.25 337	.50 1350 13	8.00 203	1.84 47	13.25 337	.50 13	45
			Vertical	1*	7.97 202	23.91 607	7.00 178	7.00 178	.48 12	...	1.81 46	20.25 514	1.19 30	7.00 178	.48 12	45
	5	SGO	Horizontal	1	19.31 490	16.19 411	9.38 238	18.00 457	.66 17	...	1.03 26	14.00 356	1.16 29	18.00 457	.66 17	98
Vertical			1*	10.75 273	34.41 874	9.38 238	9.50 241	.63 16	...	1.25 32	32.00 813	1.16 29	9.50 241	.63 16	98	
6	SHO	Horizontal	1	22.38 568	28.05 712	9.52 242	18.00 457	.77 20	...	3.83 97	21.19 538	3.03 77	18.00 457	.77 20	195	
7	SJO	Horizontal	1	24.25 616	37.25 946	13.81 351	19.75 502	1.52 39	30.00 762	310	
8736	00	SAO	Horizontal	2	7.13 181	6.91 176	5.31 135	3.41 87	.47 12	4.34 110	6.22 158	4.53 115	5.06 129	.66 17	...	13
	0	SBO	Horizontal	2	7.13 181	6.91 176	5.31 135	3.41 87	.47 12	4.34 110	6.22 158	4.53 115	5.06 129	.66 17	...	13
	1	SCO	Vertical	2*	5.41 137	11.52 293	5.31 135	5.03 128	.22 661 15	8.00 203	10.70 272	2.52 64	5.06 129	.22 6	5.03 128	13
	2	SDO	Horizontal	2	9.00 229	8.50 216	6.03 153	4.50 114	.38 10	5.63 143	7.50 191	5.00 127	5.16 131	1.50 38	...	18
			Vertical	2*	6.75 171	13.48 342	6.03 153	6.25 159	.25 678 20	10.38 264	12.97 329	3.13 80	5.16 131	.25 6	6.00 152	18
	3	SEO	Horizontal	2	12.72 323	11.72 298	7.00 178	11.75 298	.48 1248 12	10.75 273	10.75 273	11.75 298	6.25 159	.48 12	11.75 298	38
			Vertical	2*	7.31 186	22.25 565	7.00 178	6.25 159	.48 12	...	1.02 26	20.75 527	...	6.25 159	6.25 159	.48 12	6.25 159	38
	4	SFO	Horizontal	2	14.25 362	14.59 371	7.00 178	13.25 337	.50 13	...	1.84 47	12.25 311	12.25 311	13.25 337	6.25 159	.50 13	13.25 337	48
			Vertical	2*	7.97 202	26.81 681	7.00 178	7.00 178	.48 12	...	1.84 47	24.50 622	...	4.05 103	6.25 159	.48 12	7.00 178	48
	5	SGO	Horizontal	2	19.31 490	20.91 531	9.38 238	18.00 457	.66 17	...	1.28 33	19.00 483	19.00 483	18.00 457	6.63 168	.63 16	18.00 457	115
Vertical			2*	10.75 273	39.16 995	9.38 238	9.50 241	.66 17	...	1.28 33	37.25 946	37.25 946	9.50 241	6.63 168	.63 16	9.50 241	115	
6	SHO	Horizontal	2	22.38 568	28.05 712	9.52 242	18.00 457	.77 20	...	3.83 97	21.19 538	3.03 77	18.00 457	.77 20	200	
7	SJO	Horizontal	1	24.25 616	37.25 946	13.81 351	19.75 502	1.52 39	30.00 762	315	

* Vertical type design differs from that shown on the corresponding NEMA size horizontal figure, but dimensions listed apply to that figure.

Full Voltage Reversing Contactors and Starters — NEMA Approximate Dimensions – Class 8702, 8736

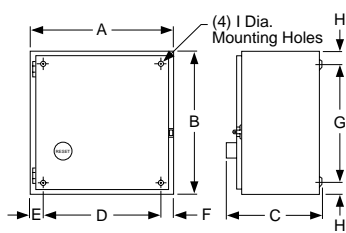

Figure 4

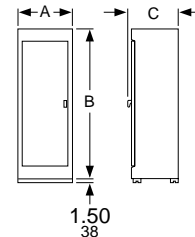

Figure 5

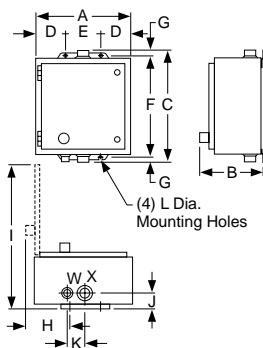

Figure 6

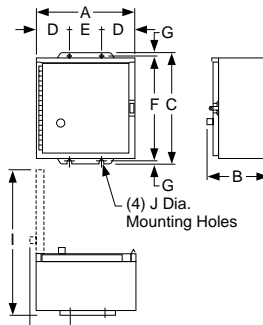

Figure 7

NEMA Type 1

NEMA Size	Class No.	Fig. No.	Dimensions — Inches/mm																		Wt (Lbs)			
			A		B		C		D		E		F		G		H		I		8702	8736		
			IN	mm	IN	mm	IN	mm	IN	mm	IN	mm	IN	mm	IN	mm	IN	mm	IN	mm				
00, 0†	8702 & 8736	4	11.88	302	11.88	302	7.41	188	7.53	191	9.75	248	1.06	27	1.06	27	9.75	248	1.06	27	.31	8	16	17
1†	8702 & 8736	4	14.88	378	14.13	359	7.56	192	7.66	195	12.75	324	1.06	27	1.06	27	12.00	305	1.06	27	.31	8	24	25
3*	8702 & 8736	4	18.16	461	29.16	741	9.25	235	9.25	235	15.50	394	1.33	34	1.33	34	26.50	673	1.33	34	.44	11	95	98
5	8702 & 8736	4	35.22	895	46.22	1174	12.81	325	12.93	328	31.00	787	2.11	54	2.11	54	42.00	1067	2.11	54	.56	14	298	315
6	8702 & 8736	5	36.22	920	62.22	1580	19.47	495	19.47	495	Floor Mounting												400	405
7	8702 & 8736	5	34.50	876	93.00	2362	23.50	597	23.50	597	Floor Mounting											

† Standard enclosure has space for a fused control transformer, Form F4T, on Sizes 0-2, except for Size 0 & 1 4-Pole.

* 3-Pole only.

NEMA Type 4 & 4X – Stainless Steel▲

NEMA Size	Class Number	Fig. No.	Dimensions — Inches/mm												Hub Dia.		Weight (Lbs)		
			A	B	C	D	E	F	G	H	I	J	K	L	W Bot. Only	X Top & Bot.	8702	8736	
			IN	mm	IN	mm	IN	mm	IN	mm	IN	mm	IN	mm	IN	mm			IN
0†	8702 & 8736	6	12.63	7.81	14.69	2.56	7.50	13.50	.59	3.88	18.41	1.66	2.31	.31	3/4	1	25	26	
1†	8702 & 8736	6	14.88	8.25	15.75	2.56	9.75	15.00	.38	3.88	20.88	1.72	2.63	.31	3/4	1 1/2	33	35	
2†	8702 & 8736	6	18.16	8.75	32.22	3.08	12.00	30.50	.88	3.69	26.72	2.56	3.19	.44	3/4	2 1/2	96	...	
3*	8702	6	18.16	8.75	32.22	3.08	12.00	30.50	.88	3.69	26.72	2.56	3.19	.44	3/4	2 1/2	96	...	
4*	8736	6	18.16	9.56	32.22	3.08	12.00	30.50	.88	4.50	26.72	2.56	3.19	.44	3/4	2 1/2	...	99	
5	8702	6	35.22	12.13	49.22	4.11	27.00	48.00	.63	4.59	45.81	2.97	3.50	.56	3/4	3 1/2	300	...	
5	8736	6	35.22	12.94	49.22	4.11	27.00	48.00	.63	5.41	45.81	2.97	3.50	.56	3/4	3 1/2	...	317	
6	8702 & 8736	5	36.22	70.13	19.47	Floor Mounting												500	505
7	8702 & 8736	5	34.50	101.00	23.50	Floor Mounting											

† Standard enclosure has space for a fused control transformer, Form F4T, on Sizes 0-2, except for Size 0 & 1 4-Pole devices.

* 3-Pole only.

▲ Size 6 & 7 are sheet steel enclosures and are rated NEMA Type 4 only.

NEMA Type 12

NEMA Size	Class Number	Fig. No.	Dimensions — Inches/mm																		Wt (Lbs)			
			A		B		C		D		E		F		G		H		I		8702	8736		
			IN	mm	IN	mm	IN	mm	IN	mm	IN	mm	IN	mm	IN	mm	IN	mm	IN	mm				
0†	8702 & 8736	7	11.88	302	7.75	197	13.75	349	2.56	65	6.75	171	12.75	324	.50	13	3.66	93	18.13	461	.31	8	23	24
1†	8702 & 8736	7	14.88	378	7.88	200	16.00	406	2.56	65	9.75	248	15.00	381	.50	13	3.66	93	21.25	540	.31	8	31	32
2†	8702 & 8736	7	18.16	461	9.25	235	31.50	800	3.08	78	12.00	305	30.50	775	.50	13	3.69	93	26.72	679	.44	11	96	...
3*	8702	7	18.16	461	9.56	243	31.50	800	3.08	78	12.00	305	30.50	775	.50	13	4.50	114	26.72	679	.44	11	...	99
4*	8736	7	18.16	461	9.56	243	31.50	800	3.08	78	12.00	305	30.50	775	.50	13	4.50	114	26.72	679	.44	11	...	99
5	8702	7	35.22	895	13.13	334	49.00	1245	4.13	105	27.00	686	48.00	1219	.50	13	5.31	135	45.88	1165	.56	14	302	...
5	8736	7	35.22	895	13.94	354	49.00	1245	4.13	105	27.00	686	48.00	1219	.50	13	6.13	156	45.88	1165	.56	14	...	319
6	8702 & 8736	5	36.22	920	62.22	1580	19.47	495	Floor Mounting												490	495		
7	8702 & 8736	5	34.50	876	93.00	2362	23.50	597	Floor Mounting													

† Standard enclosure has space for a fused control transformer, Form F4T, on Sizes 0-2, except for Size 0 & 1 4-Pole devices.

* 3-Pole only.



Full Voltage Reversing Contactors and Starters — NEMA Approximate Dimensions – Class 8702, 8736

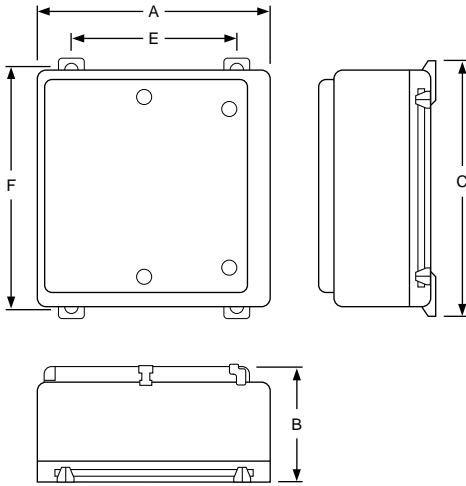

NEMA Type 4X — Watertight and Corrosion Resistant Glass Polyester Enclosure

NEMA Size	Class	Type	No. of Poles	Fig.	A		B		C		E		F	
					IN	mm	IN	mm	IN	mm	IN	mm	IN	mm
0-2	8702/36	SBW SCW SDW	All		16.88	429	9.78	248	22.75	578	10.13	257	21.50	546
0-2*	8702/36	SBW SCW SDW	All		24.63	626	11.94	303	27.00	686	17.88	454	25.75	654
3-4	8702/36	SEW SPW	All		25.81	656	11.94	303	33.50	851	18.50	470	32.25	819
3-4*	8702/36	SEW SPW	All		32.00	813	12.13	308	39.31	998	23.88	607	38.13	969

* With control power transformer (Form F4T)

Figure 7

NEMA Type 7 & 9 Bolted Enclosure — Figure 8

NEMA Size	Type	Dimensions — Inches/mm ■																		Wt (Lbs)
		G		H		J		K		L		N		P		Q, R		S, T, U, V		
		IN	mm	IN	mm	IN	mm	IN	mm	IN	mm	IN	mm	IN	mm	IN	mm	IN	mm	
0-2	SBT SCT SDT	14.25	362	27.63	702	9.50	241	12.25	311	19.25	489	9.63	245	11.50	292	2.38	60	3.13	80	115
3-4*	SET SFT	24.50	622	45.63	1159	13.75	349	22.50	572	27.50	699	13.75	349	15.38	391	3.44	87	4.00	102	180

■ Dimensions shown for 2 or 3-Pole devices only.

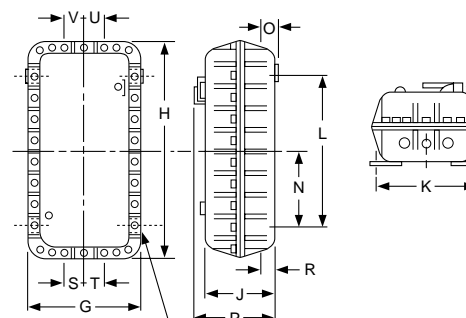

Figure 8

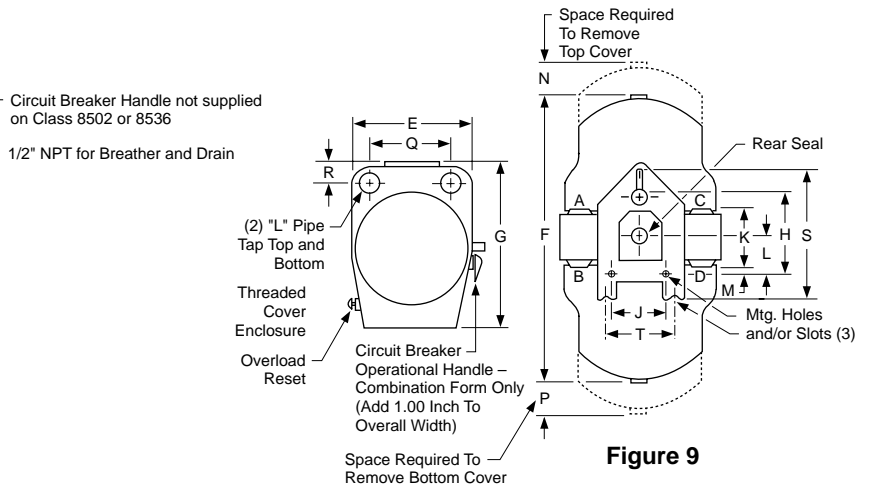

Figure 9

NEMA 7 & 9 SPIN TOP® Enclosure — Figure 9

NEMA Size	Type	Dimensions — Inches/mm																		Wt (Lbs)			
		A	B*	B†	C*	C†	D	E*	E†	F	G*	G†	H*	H†	J*	J†	K	L	M		N	P	R
0-1	SBR SCR	12.00 305	41.06 1043	46.13 1172	68.06 1729	79.13 2010	16.75 425	7.25 184	12.25 311	7.69 195	26.13 664	26.13 664	3.00 76	9.00 229	24.00 610	24.00 610	8.50 216	2.06 52	9.38 238	5.25 133	1.50 38	.38 10	70
2	SDR	16.13 410	48.50 1232	50.50 1283	81.50 2070	85.00 2159	20.25 514	12.13 308	9.13 232	8.63 219	27.75 705	32.75 832	8.00 203	4.50 114	25.00 635	30.00 762	12.00 305	12.63 321	11.00 279	5.50 140	2.50 64	.38 10	100
3	SER	Consult Local Square D Field Office																					

* Without control transformer.
† With control transformer (Form F4T).

Full Voltage Contactors — NEMA Application Data, Selection – Class 8702



Class 8702 Type WF
Reversing Vacuum
Contactor

Auxiliary Contact Units

Additional auxiliary contact units may be added to the Size 4 and 5 reversing contactors in the field. A maximum of 2 units may be added to the Size 4; a maximum of 1 unit may be added to the Size 5. No additional units may be added to the Size 6, however, 1 N.O. and 1 N.C. circuit are available on each forward and reverse contactor for customer use.

GENERAL INFORMATION

Class 8702 Type W reversing vacuum contactors are a new addition to the Square D line of contactors. These reversing contactors are used to switch capacitors, transformers and electric motors where overload protection is separately provided. Type W reversing vacuum contactors are designed for operation at 600 Volts, 50/60 Hertz.

By design, these contactors are well suited to heavy-duty applications in harsh environments. The power contacts are sealed in ceramic tubes, called vacuum interrupters or vacuum bottles, where the air has been evacuated. Arc quenchers are not required because any arc formed between opening contacts is not sustained due to the presence of the vacuum. The arc is extinguished when the current crosses zero after the contacts are opened, therefore the arc typically does not

survive more than one half cycle. There is one vacuum interrupter or bottle per pole, therefore a three pole contactor has three vacuum interrupters or bottles. The power contacts are not affected by ambient conditions or contamination. This provides for long life and reliable operation in harsh applications.

Altitude

The reversing vacuum contactor is designed to tolerate normal barometric pressure variances up to 6600 feet above sea level. If the contactor is to be used above 6600 feet above sea level, please consult the factory.

Termination Means

The Size 4 reversing vacuum contactor is supplied with line and load side lugs. The Size 5 and 6 reversing vacuum contactors are supplied without line and load side lugs. Class 9999 Type LUW5 and LUW6 lug kits are available for the Size 5 and 6 contactors. These kits include six lugs and the necessary mounting hardware.

Auxiliary Contacts

An auxiliary contact block, Class 9999 Type WX11, with one normally-open contact and normally-closed contact is used with Size 4, 5 and 6 vacuum contactors.

Class 8702 – Full Voltage Reversing Vacuum Contactors (Horizontal Only) 3-Pole Polyphase – 600 Volts AC Maximum (50-60 Hertz)

NEMA Size	Enclosed Ampere Rating	Locked Rotor Current (Amps)	Motor Volts	Max. HP	* Coil Voltage	Open Type
						Type
4	135	1080	200	40	120	WFO3V02S
			230	50	240	WFO3V03
			380	75	120	WFO3V02S
			460	100	480	WFO3V06
			575	100	600	WFO3V07
5	270	2160	200	75	120	WGO3V02S
			230	100	240	WGO3V03
			380	150	120	WGO3V02S
			460	200	480	WGO3V06
			575	200	600	WGO3V07
6	540	4320	200	150	120	WHO3V02S
			230	200	240	WHO3V03
			380	300	120	WHO3V02S
			460	400	480	WHO3V06
			575	400	600	WHO3V07

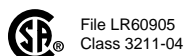

Full Voltage Contactors — NEMA Selection – Class 8702

Class 9998 – Replacement Coils for Class 8502 and 8702 Vacuum Contactors

Size	Type	Poles	Class & Type	Hertz	Suffix Number (Complete Coil Number Consists of Class and Type Followed by Suffix Number)			
				50 60	120 Volts 110 Volts	240 Volts 220 Volts	480 Volts 440 Volts	600 Volts 550 Volts
4	WF	All	9998WF					
5	WG		9998WG		120	240	480	600
6	WH		9998WH					

Class 9999 – Vacuum Contactor Kits

For Use With		Kit Description	Class 9999 Type
Type	Size		
WF-WH	4-6	Auxiliary Contacts, Non-Convertible 1-N.O. & 1-N.C. Isolated Contacts	9999WX11
WF WG-WH	4 5-6	Coil Circuit Auxiliary Contacts 1-N.O. & 1-N.C. Isolated Contacts, Delayed Break 1-N.C. Isolated Contact	9999WCX11 9999WLX01
WG WH	5 6	Lug Kits (6) lugs included (6) lugs included	9999LUW5 9999LUW6

Auxiliary Contact Ratings — NEMA A600, R300

Description	Voltage	Make	Break
Class 9999 Type WX11 and WXC01	120-600 Vac 72-120 Vac 28-72 Vac 28-300 Vac	7200 VA 60 A 60 A 28 A	720 VA 720 VA 10 A 28 VA

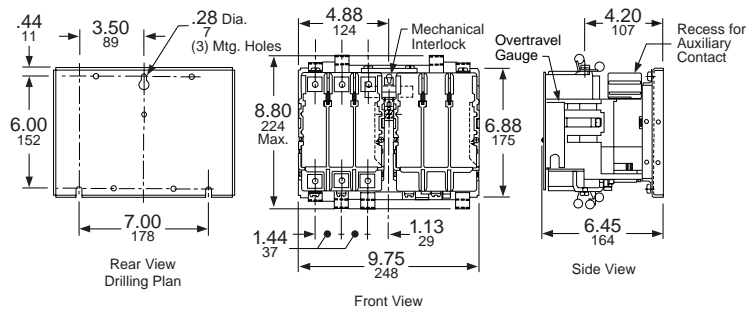

Class 8702 WF

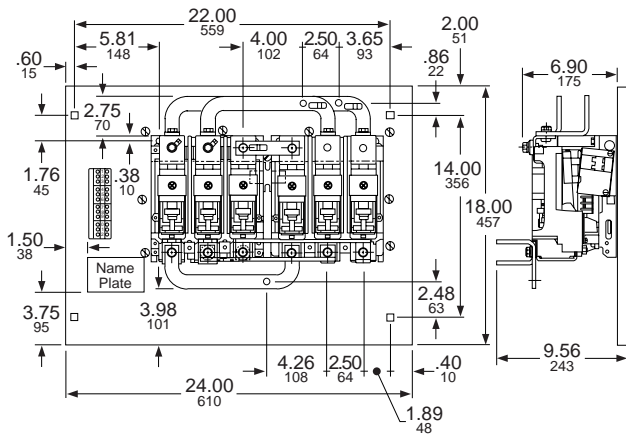

Size 5 Reversing Contactor Outline without Lugs

Class 8702 WG

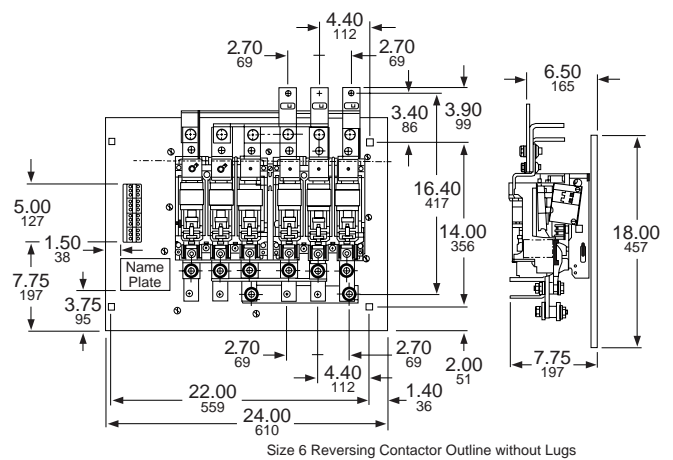

Size 6 Reversing Contactor Outline without Lugs

Class 8702 WH



SECTION 3 – MOTOR STARTERS MULTI-SPEED

Application Data – Class 8810, 8811, 8812. 40-41
Line Voltage — with Melting Alloy Overload Relays – Class 8810. 42
Reversing Line Voltage Type — with Melting Alloy Overload Relays –
Class 8810 43
Line Voltage — with Melting Alloy Overload Relays or
Solid State Overload Relays – Class 8810. 44-45
Line Voltage — with Melting Alloy Overload Relays – Class 8811, 8812. . . 48
Application Data – Class 8810, 8811, 8812. 47
Application Data for Types SB-SJ – Class 8810, 8811, 8812 48
Dimensions – Class 8810, 8811, 8812 49
Application Data – Class 8810, 8811, 8812. 50-51
Disconnect Switch or Circuit Breaker Type – Class 8810, 8811, 8812 . . . 52



AC Multispeed Magnetic Starters

Application Data – Class 8810, 8811, 8812

Typical Schematic Diagrams

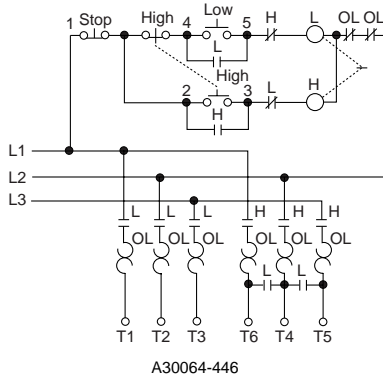

A30064-446
2-Speed Consequent Pole Constant Horsepower
NEMA Size 0-4
Sizes 5, 6 & 7 Use Special Circuitry

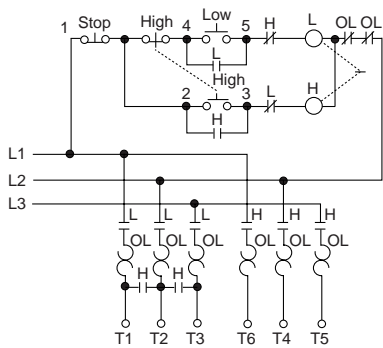

A30064-442
2-Speed Consequent Pole Constant or Variable Torque
NEMA Size 0-4
Sizes 5, 6 & 7 Use Special Circuitry

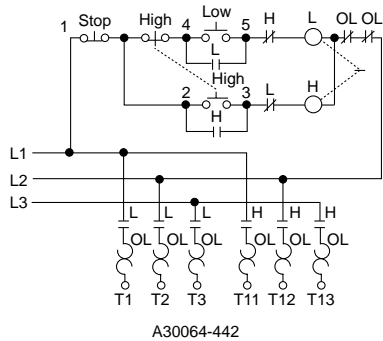

A30064-442
2-Speed Separate Winding Constant HP, Constant Torque
and Variable Torque NEMA Size 0-4
Sizes 5, 6 & 7 Use Special Circuitry

Multispeed motors are available in two basic versions:

- Consequent pole
- Separate winding

A separate winding motor has a winding for each speed while a consequent pole motor has a winding for every two speeds (three speed motors have two windings). The motor connections (and thus the types of controllers) for two speed starters are exemplified by the schematic diagrams shown to the left. Note that consequent pole two speed controllers involve a 5-pole and a 3-pole starter while separate winding controllers have two 3-pole starters.

Separate winding motors are usually chosen when flexibility is important, since the speeds of a consequent pole motor are usually limited to a 2/1 ratio; a broad range of speeds can be obtained on a separate winding motor.

Both consequent pole and separate winding motors are available in three types:

- Constant horsepower
- Constant torque
- Variable torque

Typical applications for these different types of motors are shown below.

NOTE: For detailed information involving the technical aspects of flexibility of the starters used in the multispeed controllers, see Classes 8702, 8736 and 8810 application data.

Typical Applications

Constant H.P.

- Spindles
- Cutting Tools
 - Lathes
 - Saws

Constant Torque

- Conveyors
- Mills
- Dough Mixers
- Reciprocating Pumps

Variable Torque

- Fans
- Centrifugal Pumps

Speed Selection

The speed of a squirrel cage motor is directly proportional to the power supply frequency and inversely proportional to the number of poles in the stator winding. With the frequency constant, motor speed is determined by the number of poles.

$$\text{(RPM) Speed} = \frac{(120) (\text{Frequency})}{\text{No. of Poles}}$$

$$\text{Horsepower} = \frac{T \times S}{5250} \quad \text{Where:}$$

T = Torque in Lb Ft
S = Speed in RPM

AC Multispeed Magnetic Starters

Application Data – Class 8810, 8811, 8812

Special Pilot Lighting

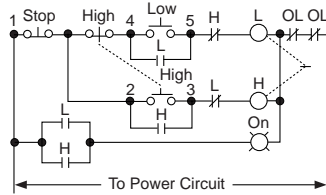

A30080-017

One pilot light "ON"

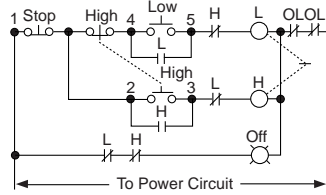

A30080-018

One pilot light "OFF"

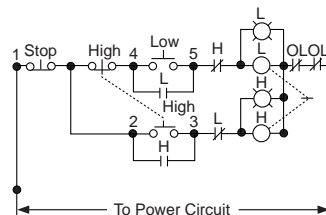

A30080-015

Two pilot lights "L" and "H"

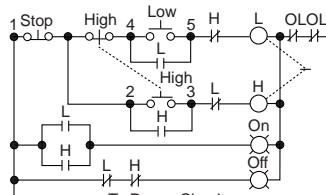

A30080-016

Two pilot lights "ON" and "OFF"

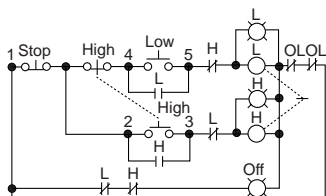

A30080-019

Three pilot lights "L", "H" and "OFF"

ADDITIONAL FEATURES

Special Relays for Non-Reversing and Reversing Multispeed Starters

General

Standard starters are not equipped with any special relays to require starting at lowest speed, progressive acceleration or deceleration through each speed, etc. However, when the type of motor or characteristics of the load involved make certain starting or control sequences necessary, four types of relays/timers are available to accomplish the required function.

Form R1 Compelling Relay

This relay makes it necessary for the motor to be started at low speed before any higher speed can be selected. Pressing any push button except the low speed will not start the motor. This arrangement insures that the motor will always start the load at low speed. The stop button must be pressed before it is possible to change from a higher to a lower speed.

Form R2 Accelerating Relay/Timer

When the starter is equipped with Form R2 accelerating relays, the ultimate speed is determined by the button which is pressed, but the starter will start the motor at low speed and then automatically accelerate it through successive steps until the selected speed is reached. Definite time intervals must elapse between each speed change. Individual timing relays are provided for each interval, and all are adjustable. The stop button must be pressed before it is possible to change from a higher to a lower speed.

Form R3 Decelerating Relay/Timer

This is similar in action to Form R2 accelerating relays, except that they function to prevent immediate transfer from a higher to a lower speed. A definite time interval, preset on the timer, must elapse between each speed change.

Form R10 Antiplugging Relays/Timers

If it is necessary to have an imposed time delay when transferring from the forward to the reverse direction or reverse to forward, then Form R10 should be included in the form designation of the **reversing** multispeed starters. This provides up to a 60 second delay in the transfer of the direction of the motor, and can help prevent damage which could result from plugging.



AC Two Speed Magnetic Starters

Line Voltage — with Melting Alloy Overload Relays – Class 8810



Class 8810, Type S
in NEMA Type 1 Enclosure

Line voltage type, ac two speed starters are designed to control reconnectable squirrel cage motors to operate at two different constant speeds, depending upon their construction. The use of an automatic starter and proper control station permits greater operating efficiency and offers protection to both motor and machine against improper sequencing or too rapid speed change. Protection against motor overload in each speed is provided by an overload relay block which accepts three (3) thermal units.

Class 8810 Non-reversing – Two Speed – 50-60 Hertz – 600 Volts Maximum

Type of Motor	NEMA Size	Maximum Polyphase Horsepower Ratings						General Purpose Enclosure NEMA Type 1	Watertight and Dusttight Enclosure (Stainless Steel) (Sizes 0-5 only) Size 6 Sheet Steel NEMA Type 4	For Hazardous Locations Class I Groups C & D Class II Groups E, F & G NEMA Types 7 and 9	Dusttight and Driptight Industrial Use Enclosure NEMA Type 12†	Open Type				
		Constant Horsepower Motors			Constant Torque or Variable Torque Motors								Type	Type	Type	Type
		200 V	230 V	460-575 V	200 V	230 V	460-575 V									
Single Winding (Consequent Pole) 5-Pole – 3-Pole																
Constant HP	0	2	2	3	SBG-1	SBW-1▲	...	SBA-1▲	SBO-1					
	1	5	5	7½	SCG-1	SCW-1▲	SCR-1●	SCA-1▲	SCO-1					
	2	7½	10	20	SDG-1	SDW-1	SDR-1●	SDA-1	SDO-1					
	3	20	25	40	SEG-1	SEW-1	SER-1●	SEA-1	SEO-1					
	4	30	40	75	SFG-1	SFW-1	...	SFA-1	SFO-1					
	5	60	75	150	SGG-1	SGW-1	...	SGA-1	SGO-1					
Constant Torque or Variable Torque	0	3	3	5	SBG-2	SBW-2▲	...	SBA-2▲	SBO-2					
	1	7½	7½	10	SCG-2	SCW-2▲	SCR-2●	SCA-2▲	SCO-2					
	2	10	15	25	SDG-2	SDW-2	SDR-2●	SDA-2	SDO-2					
	3	25	30	50	SEG-2	SEW-2	SER-2●	SEA-2	SEO-2					
	4	40	50	100	SFG-2	SFW-2	...	SFA-2	SFO-2					
	5	75	100	200	SGG-2	SGW-2	...	SGA-2	SGO-2					
Two Winding (Separate Winding) 3-Pole – 3-Pole♦	0	2	2	3	SBG-3	SBW-3▲	...	SBA-3▲	SBO-3					
	1	5	5	7½	SCG-3	SCW-3▲	SCR-3●	SCA-3▲	SCO-3					
	2	7½	10	20	SDG-3	SDW-3	SDR-3●	SDA-3	SDO-3					
	3	20	25	40	SEG-3	SEW-3	SER-3●	SEA-3	SEO-3					
	4	30	40	75	SFG-3	SFW-3	...	SFA-3	SFO-3					
	5	60	75	150	SGG-3	SGW-3	...	SGA-3	SGO-3					
	6	100	150	300	SHG-3	SHW-3	...	SHA-3	SHO-3					
7	...	225	450	SJG-3	SJA-3	SJO-3						
Constant Torque or Variable Torque♦	0	3	3	5	SBG-4	SBW-4▲	...	SBA-4▲	SBO-4					
	1	7½	7½	10	SCG-4	SCW-4▲	SCR-4●	SCA-4▲	SCO-4					
	2	10	15	25	SDG-4	SDW-4	SDR-4●	SDA-4	SDO-4					
	3	25	30	50	SEG-4	SEW-4	SER-4●	SEA-4	SEO-4					
	4	40	50	100	SFG-4	SFW-4	...	SFA-4	SFO-4					
	5	75	100	200	SGG-4	SGW-4	...	SGA-4	SGO-4					
	6	150	200	400	SHG-4	SHW-4	...	SHA-4	SHO-4					
7	300	600	...	SJG-4	SJA-4	SJO-4						

- ♦ Type numbers shown for three phase separate winding motor starters apply only when motor windings are wye connected. When motor windings are connected open delta use three phase consequent pole motor starters.
- ▲ Separate NEMA Type 4 and 12 enclosures available.
- † NEMA Type 12 enclosures may be field modified for outdoor applications.
- NEMA Type 4X enclosures available; consult local Square D field office.
- Addition of forms to standard NEMA Type 7 and 9 enclosed devices is limited. Consult local Square D field office.

380 Volts, 50 Hertz – above type numbers will apply to starters for 380 volt, 50 hertz but the selection by NEMA size must be based on the horsepower ratings in the following table:

NEMA Size	0	1	2	3	4	5	6
Constant Horsepower	3	7½	20	40	60	100	200
Constant or Variable Torque Horsepower	5	10	25	50	75	150	300

Thermal Units

Thermal units should be ordered separately. See Thermal Unit Selection Index. **Do not use horsepower rating(s) for thermal unit selection. All three phase two speed magnetic starters require six (6) thermal units, three per speed.** Use nameplate FLC's (Full Load Currents) from motor nameplate.

Special Features — See Factory Modifications and Forms, Catalog 9999CT9701.

Dimensions — See Pages 49-52.

Field Modification Kits — See Catalog 9999CT9701 Section.

Class 8810, 8811 and 8812 multispeed starters, both non-reversing and reversing versions, are available with either circuit breaker or disconnect switch. Refer to Factory Modifications and Forms for Form numbers and price additions.

How to Order:

To Order Specify:	Catalog Number			
• Class Number	Class	Type	Coil Voltage Code	Form(s)
• Type Number				
• Coil Voltage Code				
• Form(s)				
	8810	SCO8	VO6	P1S



File E78351
CCN NLDX



File LR60905
Class 3211-04



AC Reversing Two Speed Magnetic Starters Line Voltage Type — with Melting Alloy Overload Relays – Class 8810

Class 8810 AC reversing two speed starters combine the functions of reversing and speed selection in one controller. The units are electrically and mechanically interlocked, and include motor running overcurrent protection. Typical applications include conveyors, drilling and tapping machines, and cooling tower fans. Many of these applications also require the special relay features.

Class 8810 – Reversing – 50-60 Hertz – 600 Volts Maximum

Type of Motor	NEMA Size	Maximum Polyphase Ratings						Reversing In One Speed Only			Reversing In Both Speeds		
		Constant Horsepower Motors			Constant Torque or Variable Torque Motors			General Purpose Enclosure NEMA Type 1	Dusttight and Driptight Industrial Use Enclosure NEMA Type 12 (Type 3 and 3R)♦	Open Type	General Purpose Enclosure NEMA Type 1	Dusttight and Driptight Industrial Use Enclosure NEMA Type 12 (Type 3 and 3R)♦	Open Type
		200 V	230 V	460-575 V	200 V	230 V	460-575 V	Type★	Type★	Type★	Type	Type	Type
Single Winding Constant Horsepower	0	2	2	3	SBG-21	SBA-21	SBO-21	SBG-31	SBA-31	SBO-31
	1	5	5	7½	SCG-21	SCA-21	SCO-21	SCG-31	SCA-31	SCO-31
	2	7½	10	20	SDG-21	SDA-21	SDO-21	SDG-31	SDA-31	SDO-31
	3	20	25	40	SEG-21	SEA-21	SEO-21	SEG-31	SEA-31	SEO-31
	4	30	40	75	SFG-21	SFA-21	SFO-21	SFG-31	SFA-31	SFO-31
5	60	75	150	SGG-21	SGA-21	SGO-21	SGG-31	SGA-31	SGO-31	
Single Winding Constant Torque or Variable Torque	0	3	3	5	SBG-22	SBA-22	SBO-22	SBG-32	SBA-32	SBO-32
	1	7½	7½	10	SCG-22	SCA-22	SCO-22	SCG-32	SCA-32	SCO-32
	2	10	15	25	SDG-22	SDA-22	SDO-22	SDG-32	SDA-32	SDO-32
	3	25	30	50	SEG-22	SEA-22	SEO-22	SEG-32	SEA-32	SEO-32
	4	40	50	100	SFG-22	SFA-22	SFO-22	SFG-32	SFA-32	SFO-32
5	75	100	200	SGG-22	SGA-22	SGO-22	SGG-32	SGA-32	SGO-32	
Constant Horsepower	0	2	2	3	SBG-23	SBA-23	SBO-23	SBG-33	SBA-33	SBO-33
	1	5	5	7½	SCG-23	SCA-23	SCO-23	SCG-33	SCA-33	SCO-33
	2	7½	10	20	SDG-23	SDA-23	SDO-23	SDG-33	SDA-33	SDO-33
	3	20	25	40	SEG-23	SEA-23	SEO-23	SEG-33	SEA-33	SEO-33
	4	30	40	75	SFG-23	SFA-23	SFO-23	SFG-33	SFA-33	SFO-33
5	60	75	150	SGG-23	SGA-23	SGO-23	SGG-33	SGA-33	SGO-33	
Constant Torque or Variable Torque	0	3	3	5	SBG-24	SBA-24	SBO-24	SBG-34	SBA-34	SBO-34
	1	7½	7½	10	SCG-24	SCA-24	SCO-24	SCG-34	SCA-34	SCO-34
	2	10	15	25	SDG-24	SDA-24	SDO-24	SDG-34	SDA-34	SDO-34
	3	25	30	50	SEG-24	SEA-24	SEO-24	SEG-34	SEA-34	SEO-34
	4	40	50	100	SFG-24	SFA-24	SFO-24	SFG-34	SFA-34	SFO-34
5	75	100	200	SGG-24	SGA-24	SGO-24	SGG-34	SGA-34	SGO-34	

† Prices and Type numbers shown for three phase, separate winding motor starters apply only when motor windings are wye connected. When motor windings are connected open delta use the prices shown for consequent pole motor starters.

▲ Specify the speed which requires reversing by adding an L (low) or an H (high) after the type number, e.g. A Class 8810 Type SBG-21 with reversing in low only would be ordered as a Class 8810 Type SBG-21L.

♦ NEMA Type 12 enclosures may be field modified for outdoor applications. For details refer to Class 9991.

Typical Elementary Diagrams

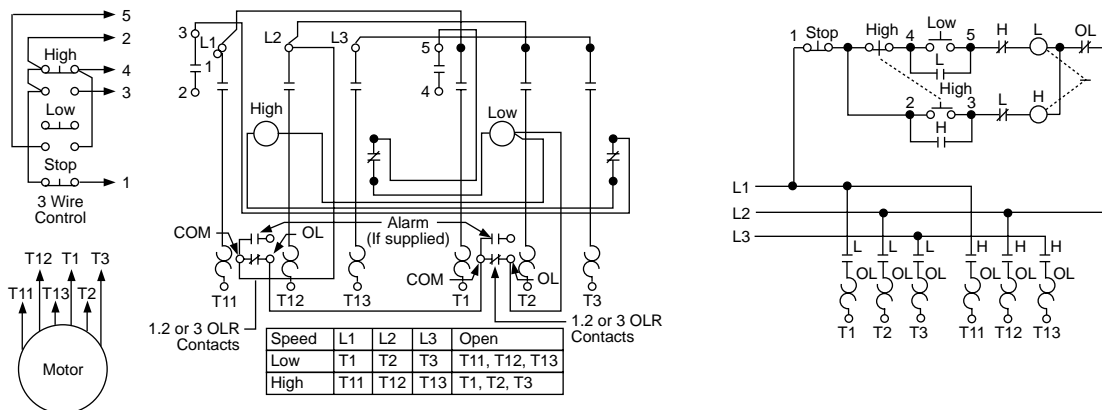

How to Order:

To Order Specify:	Catalog Number			
• Class Number	Class	Type	Coil Voltage Code	Form(s)
• Type Number	8810	SCO8	VO6	P1S
• Coil Voltage Code				
• Form(s)				

Thermal Units

Thermal units should be ordered separately. See Thermal Unit Selection Index. **Do not use horsepower rating(s) for thermal unit selection. All three phase two speed magnetic starters require six (6) thermal units, three per speed.** Use nameplate FLC's (Full Load Currents) from motor nameplate.



AC Two Speed Magnetic Starters

Line Voltage — with Melting Alloy Overload Relays or Solid State Overload Relays – Class 8810

Class 8810 — Non-Reversing — Horizontally Arranged Starters

▲†Glass Polyester Watertight, Dusttight and Corrosion Resistant Enclosure

50-60 Hertz – 600 Volts Maximum

Type of Motor	NEMA Size	Maximum Horsepower Ratings				For Consequent Pole Motors	For Separate Winding Motors
		200 V	230 V	380 V	460-575 V	Type	Type
Constant Horsepower	0	2	2	3	3	SBW-51	SBW-53
	1	5	5	7½	7½	SCW-51	SCW-53
	2	7½	10	20	20	SDW-51	SDW-53
	3	20	25	40	40	SEW-51	SEW-53
	4	30	40	60	75	...	SFW-53
Constant Torque or Variable Torque	0	3	3	5	5	SBW-52	SBW-54
	1	7½	7½	10	10	SCW-52	SCW-54
	2	10	15	25	25	SDW-52	SDW-54
	3	25	30	50	50	SEW-52	SEW-54
	4	40	50	75	100	...	SFW-54

▲ NEMA Type 4X hubs are included with each starter at no additional cost.

† Combination features available – consult factory.

Vertically Arranged, Open Type, Two Speed Starters

Vertically arranged starters are used where width limitations prevent the use of the conventional horizontally arranged device. Such starters may be used to advantage in threaded NEMA Type 7 explosion-proof enclosures, and in multi-motor panels in which other equipment within the enclosure used limits the available width.

These starters have all the features of the standard horizontally arranged devices, but the two contactors are in a vertical arrangement. These starters are offered in open type construction only.

Class 8810 — Non-Reversing — Vertically Arranged Starters – 50 or 60 Hertz – 600 Volts Maximum

Type of Motor	NEMA Size	Maximum Horsepower Ratings				For Consequent Pole Motors	For Separate Winding Motors
		200 V	230 V	380 V	460-575 V	Type	Type
Constant Horsepower	0	2	2	3	3	SBO-11	SBO-13
	1	5	5	7½	7½	SCO-11	SCO-13
	2	7½	10	20	20	SDO-11	SDO-13
	3	20	25	40	40	SEO-11	SEO-13
	4	30	40	60	75	SFO-11	SFO-13
Constant Torque or Variable Torque	0	3	3	5	5	SBO-12	SBO-14
	1	7½	7½	10	10	SCO-12	SCO-14
	2	10	15	25	25	SDO-12	SDO-14
	3	25	30	50	50	SEO-12	SEO-14
	4	40	50	75	100	SFO-12	SFO-14

How to Order:

<p>To Order Specify:</p> <ul style="list-style-type: none"> • Class Number • Type Number • Coil Voltage Code • Form(s) 	<p>Catalog Number</p> <table border="1"> <tr> <td>Class</td> <td>Type</td> <td>Coil Voltage Code</td> <td>Form(s)</td> </tr> <tr> <td>8810</td> <td>SCO8</td> <td>VO6</td> <td>P1S</td> </tr> </table>	Class	Type	Coil Voltage Code	Form(s)	8810	SCO8	VO6	P1S
Class	Type	Coil Voltage Code	Form(s)						
8810	SCO8	VO6	P1S						

Thermal Units

Thermal units should be ordered separately. For selection of thermal units, refer to the Catalog Thermal Unit Selection Index, Digest or Bulletin SM-416, entitled "Application and Selection of Overload Relays." Do not use horsepower rating(s) for thermal unit selection. All three phase two speed magnetic starters require six (6) thermal units, three per speed. Use nameplate FLC's (Full Load Currents) from motor nameplate.



AC Two Speed Magnetic Starters Line Voltage — with Melting Alloy Overload Relays or Solid State Overload Relays – Class 8810

Special Arrangements with Three Devices

Three Type S Contactors can be mechanically interlocked so that only one contactor can be energized at any one time. The mechanical interlock, pictured in Figure 2, is an interference (non-jamming) type locking at the beginning of the stroke of any contactor.

Factory assembled units are listed in the table below. Figures 1 and 2 show factory assembled and wired devices. All contactors are both electrically and mechanically interlocked. The class and type numbers listed only cover the contactor and/or starter mounting arrangement, NEMA size of the devices, and the number of poles. A power and control wiring diagram must accompany each order. Additional electrical interlocks are available factory (or field) installed in the locations shown in Figure No. 2 and Table No. 2, Page 52. 8810 starters are supplied with melting alloy type thermal overload relays.

For customer assembled units, the basic mechanical interlock and base assembly can be purchased separately. Standard Class 8502 contactors and Class 8536 starters are used in the locations and pole arrangement shown. If Class 8536 starters are used, it is necessary to mount a Class 9999 Type SO bracket below the overload block to give the block support.

For electrically interlocking customer assembled units a Class 9999 Type SX-12, normally closed internal interlock and/or a Class 9999 Type SX-7, normally closed external interlock can be used.

Three Mechanically Interlocked Contactors and Starters — Factory Assembled

Class	Type	Contactor Position — See Figure 2						Overload Relay Position See Fig. 3	Number of Thermal Units Required
		No. 1 Contactor		No. 2 Contactor		No. 3 Contactor			
		NEMA Size 1 No. of Poles	NEMA Size 2 No. of Poles	NEMA Size 1 No. of Poles	NEMA Size 2 No. of Poles	NEMA Size 1 No. of Poles	NEMA Size 2 No. of Poles		
8810	SCO-41	3	...	3	...	3	...	OL-2 & -3	6
	SCO-42	4	...	3	...	3	...		
	SCO-43	...	3	3	...	3	...		
	SCO-44	...	4	3	...	3	...		
	SDO-41	...	3	...	3	...	3		
8810	SCO-45	3	...	3	...	5	...	OL-2 & -3	6
	SCO-46	4	...	3	...	5	...		
	SCO-47	...	3	3	...	5	...		
	SCO-48	...	4	3	...	5	...		
	SDO-43	...	3	...	3	...	5		
			4	...	3	...	5		

Ordering Information Required

- Order complete factory assembled devices by class and type number from table above.
- Supply wiring diagram for power and control connections as catalog number only covers general contactor and starter mounting arrangement.
- Voltage and frequency of contactor coils.
- Select additional factory assembled electrical interlocks from table on Page 47 specifying interlock position letter and whether interlock is N.O. or N.C.
- Example of ordering information required on factory assembled devices:
 - Class 8810 Type SCO-45

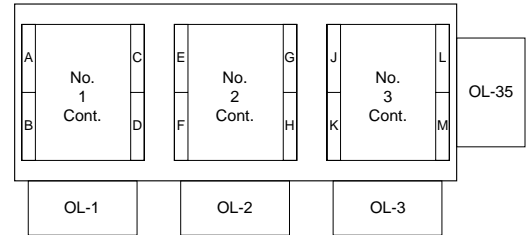

Figure 2
Contactor, overload and external electrical interlock positions

- Wired per diagram (which must accompany order)
 - All coils — 120 volts, 60 hertz
 - Additional electrical interlocks:
C — N.O., E — N.C., and J — N.O.
- For customer assembly of three mechanically interlocked devices, order the mechanical interlock and overload relay mounting brackets by class and type numbers.

Thermal Units

Thermal units should be ordered separately. For selection of thermal units, refer to the Catalog Thermal Unit Selection Index R Digest. Use the motor nameplate FLC's (Full Load Currents) to select thermal units.



Three and Four Speed AC Magnetic Starters Line Voltage — with Melting Alloy Overload Relays – Class 8811, 8812

Class 881 and 8812 line voltage starters are designed to control 3 and 4 speed motors, respectively. The use of an automatic starter and proper control station permits greater efficiency. The addition of compelling relays to a starter gives protection to both the motor and the machine against an improper sequence or a too rapid change in speed. The motor is protected against excessive operating currents by overload relay blocks (one for each motor speed) each of which accepts three (3) thermal units. While the starters listed are for use with consequent pole motors only, separate winding motor starters are also available upon request.

Class 8811 — Three Speed AC Magnetic Starters — Consequent Pole, 2 Winding 600 Volts Maximum — 50-60 Hertz

Type of Motor	NEMA Size	Maximum Horsepower			General Purpose Enclosure NEMA Type 1	Watertight and Dusttight Enclosure (Stainless Steel) NEMA Type 4	Dusttight and Driptight Industrial Use Enclosure NEMA Type 12 (Type 3 and 3R)†	Open Type
		200 V	230 V	460-575 V				
Constant Horsepower	0	2	2	3	SBG-1	SBW-1	SBA-1	SBO-1
	1	5	5	7½	SCG-1	SCW-1	SCA-1	SCO-1
	2	7½	10	20	SDG-1	SDW-1	SDA-1	SDO-1
	3	20	25	40	SEG-1	SEW-1	SEA-1	SEO-1
Constant Torque	4	30	40	75	SFG-1	SFW-1	SFA-1	SFO-1
	0	3	3	5	SBG-2	SBW-2	SBA-2	SBO-2
	1	7½	7½	10	SCG-2	SCW-2	SCA-2	SCO-2
	2	10	15	25	SDG-2	SDW-2	SDA-2	SDO-2
Variable Torque	3	25	30	50	SEG-2	SEW-2	SEA-2	SEO-2
	4	40	50	100	SFG-2	SFW-2	SFA-2	SFO-2
	0	3	3	5	SBG-3	SBW-3	SBA-3	SBO-3
	1	7½	7½	10	SCG-3	SCW-3	SCA-3	SCO-3
Variable Torque	2	10	15	25	SDG-3	SDW-3	SDA-3	SDO-3
	3	25	30	50	SEG-3	SEW-3	SEA-3	SEO-3
	4	40	50	100	SFG-3	SFW-3	SFA-3	SFO-3

Class 8812 — Four Speed AC Magnetic Starters — Consequent Pole, 2 Winding 600 Volts Maximum — 50-60 Hertz

Type of Motor	NEMA Size	Maximum Horsepower			General Purpose Enclosure NEMA Type 1	Watertight and Dusttight Enclosure (Stainless Steel) NEMA Type 4	Dusttight and Driptight Industrial Use Enclosure NEMA Type 12 (Type 3 and 3R)†	Open Type
		200 V	230 V	460-575 V				
Constant Horsepower	0	2	2	3	SBG-1	SBW-1	SBA-1	SBO-1
	1	5	5	7½	SCG-1	SCW-1	SCA-1	SCO-1
	2	7½	10	20	SDG-1	SDW-1	SDA-1	SDO-1
	3	20	25	40	SEG-1	SEW-1	SEA-1	SEO-1
Constant Torque	4	30	40	75	SFG-1	SFW-1	SFA-1	SFO-1
	0	3	3	5	SBG-2	SBW-2	SBA-2	SBO-2
	1	7½	7½	10	SCG-2	SCW-2	SCA-2	SCO-2
	2	10	15	25	SDG-2	SDW-2	SDA-2	SDO-2
Variable Torque	3	25	30	50	SEG-2	SEW-2	SEA-2	SEO-2
	4	40	50	100	SFG-2	SFW-2	SFA-2	SFO-2
	0	3	3	5	SBG-3	SBW-3	SBA-3	SBO-3
	1	7½	7½	10	SCG-3	SCW-3	SCA-3	SCO-3
Variable Torque	2	10	15	25	SDG-3	SDW-3	SDA-3	SDO-3
	3	25	30	50	SEG-3	SEW-3	SEA-3	SEO-3
	4	40	50	100	SFG-3	SFW-3	SFA-3	SFO-3

† NEMA Type 12 enclosures may be field modified for outdoor applications.

Thermal Units

Thermal units should be ordered separately. For selection of thermal units, refer to the Catalog Thermal Unit Selection Index R Digest. All starters require the use of three (3) thermal units for each speed of the motor. Do not use the horsepower rating(s) for selection. Use nameplate FLC's (Full Load Currents) from motor nameplate.

How to Order:

To Order Specify:	Catalog Number			
• Class Number	Class	Type	Coil Voltage Code	Form(s)
• Type Number	8810	SCO8	VO6	P1S
• Coil Voltage Code				
• Form(s)				

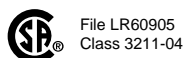

AC Multispeed Magnetic Starters

Application Data – Class 8810, 8811, 8812

Application Data for Types SB-SH

Form Designations for Factory Installation of Electrical Interlocks

		Additional Electrical Interlocks on High Starter						
		Standard (No Additional Interlocks)	Change N.O. Holding Circuit Interlock to N.C.	1 N.O.	1 N.C.	2 N.O.	1 N.O.-1 N.C.	2 N.C.
Additional Electrical Interlocks on Low Starter	Standard (No Additional Interlocks)		X01	X02	X03	X05	X06	X07
	Change N.O. Holding Circuit Interlock to N.C.	X10	X11	X12	X13	X15	X16	X17
	1 N.O.	X20	X21	X22	X23	X25	X26	X27
	1 N.C.	X30	X31	X32	X33	X35	X36	X37
	2 N.O.	X50	X51	X52	X53	X55	X56	X57
	1 N.O.-1 N.C.	X60	X61	X62	X63	X65	X66	X67
	2 N.C.	X70	X71	X72	X73	X75	X76	X77

Control Transformer Selection

The following table gives the proper size control transformer to be used with a given reversing device, with or without additional electrical interlocks or timer.

NEMA Size	Type	No. of Poles	Transformer* Class 9070 Type
0, 1 & 2	SB, SC & SD	Any	EO-2 or GO-2
3	SE	3	EO-3 or GO-3
		4 & 5	EO-4
4	SF	Any	EO-4
5	SG	Any	▲
6	SH	Any	‡
7	SJ	Any	†

- * If a different manufacturer's transformer is to be used, check its suitability for use with coil loads. See inrush and sealed VA ratings of the contactor coil.
- ▲ Standard engineering practice for Size 5 contactors is to use a Class 9070 Type EO-1 transformer and Class 8501 Type DO-20 control relay.
- ‡ A Class 9070 Type EO-3S2 transformer is an integral part of the Size 6 control circuit providing 120 volt control circuit voltage as standard on devices wired for common control.
- † A Class 9070 Type EO-19-S2 transformer is an integral part of the size 7 control circuit providing 120 volt control circuit voltage as standard on devices wired for common control.

Maximum Number of Auxiliary Units

NEMA Size (Type)	No. of Poles of Basic Contactor	Maximum number of auxiliary units on each contactor, forward or reverse, (in addition to internal holding circuit and electrical interlocks).
00, 0, 1 and 2 (SA, SB, SC and SD)	2 or 3	4 single circuit external interlocks (N.O. or N.C.) 1 single circuit external interlock (N.O. or N.C.) plus 1 attached timer (ON or OFF delay).
	4	2 single circuit external interlocks (N.O. or N.C.)
3, 4, 5 and 6 (SE, SF, SG and SH)	Any	2 single circuit external interlocks (N.O. or N.C.) 1 single circuit external interlock plus 1 attached timer (ON or OFF delay).
7 (SJ)	Any	Consult local Square D field office

AC Magnet Coils for AC Contactors and Starters

Devices Using Coil			Coil Specification Number	Suffix Numbers (Complete coil part number consists of specification number followed by suffix number as 31041-400-51.)							
NEMA Size	Type	Poles		24 V/60 Hz	120 V/60 Hz 110 V/50 Hz	208 V/60 Hz	220 V/60 Hz	240 V/60 Hz 220 V/50 Hz	277 V/60 Hz	480 V/60 Hz 440 V/50 Hz	600 V/60 Hz 550 V/50 Hz
00	SA	All	31041-400-	20	42	48	‡	51	52	60	62
0	SB	All	31041-400-	20	42	48	‡	51	52	60	62
1	SC	All	31041-400-	20	42	48	‡	51	52	60	62
		3	31063-409-	16	38	44	‡	47	49	57	60
2	SD	4-5	31063-400-	16	38	44	‡	47	49	57	60
		3	31074-400-	16	38	44	‡	47	49	57	60
3	SE	4-5	31091-400-	16	38	44	‡	47	49	57	60
		3	31091-400-	16	38	44	‡	47	49	57	60
4	SF	All	31091-400-	16	38	44	‡	47	49	57	60
5	SG	3	31096-400-	...	09	15	‡	18	19	24	29
6	SH	3	31104-400-50 (all voltages)								
7	SJ	3	31104-400-50 (all voltages)								

‡ For 220 volt and 230 volt, 60 hertz applications, use 240 volt coil.



AC Multispeed Magnetic Starters

Application Data for Types SB-SJ – Class 8810, 8811, 8812



Class 9999 Type SM-1
Mechanical Interlock For
Two Contactors
Horizontally Mounted



Class 9999 Type SM-12
For Sizes 3 and 4
Horizontally Mounted

MECHANICAL INTERLOCK

General

Type S contactors or starters can be mechanically interlocked so that only one device will be energized at a time. The mechanical interlock is an interference (non-jamming) type, locking at the beginning of the stroke of any starter or contactor.

Overload Relay Mounting Bracket

Mechanical interlock Types SM-1 through SM-10 for Sizes 00-2 devices use overload relay mounting brackets to support the overload relay portion of the starter.

Type S Sizes 00, 0, 1 and 2

The mechanical interlock is mounted on the underside of the reversing baseplate. Two pins extend from the mechanical interlock through openings in the baseplate and engage the contact carrier of each contactor. Two styles of mechanical interlocks are used: one version for

three pole contactors, a different version for four or five pole contactors. **When adding a power pole to an existing three pole reversing contactor, a new mechanical interlock must also be installed.**

Three unit mechanically interlocked contactors and/or starters are also available for various combinations of Sizes 0, 1 and 2.

Type S Sizes 3, 4, 5 and 6

The mechanical interlock is separate from the mounting pan on Sizes 3-6. Cams on the mechanical interlocks are operated by the contact carrier of each contactor. The mechanical interlock is attached to the underside of the two contactors on Sizes 3 and 4; directly to the mounting pan on sizes 5 and 6. Size 5 and 6 mechanical interlocks are sold only as a factory assembly with the 8810 starter.

The mechanical interlock utilizes a special baseplate and bracket that connects between the armatures. This is sold only as a factory assembly with the 8810 starter.

Mechanical Interlock for Two Contactors

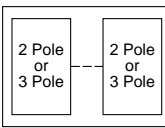
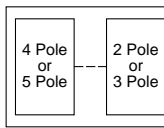
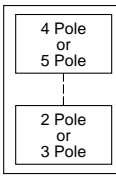
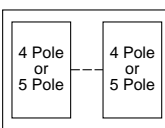
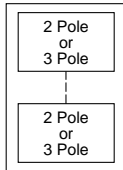
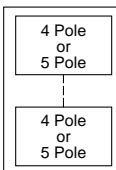
Kit Description – The following kits consist of the mechanical interlock and base assembly for interlocking 2-5 pole contactors. Mechanical interlocks for horizontal and vertical mounting are listed for various pole arrangements.			Contactor NEMA Size	Class 9999 Type
 <p>Horizontal Type SM-1 for Size 00†, 0, or 1 Type SM-6 for Size 2 Type SM-12 for Sizes 3 & 4</p>	 <p>Horizontal* Type SM-2 for Size 0 or 1 Type SM-7 for Size 2 Type SM-12 for Sizes 3 & 4</p>	 <p>Vertical* Type SM-2 for Size 0 or 1 Type SM-10 for Size 2 Type SM-11 for Size 3 Type SM-13 for Size 4</p>	00†, 0, 1 0, 1 0, 1 0, 1 0, 1	SM-1 SM-2* SM-3 SM-4 SM-5
 <p>Horizontal Type SM-3 for Size 0 or 1 Type SM-8 for Size 2 Type SM-12 for Sizes 3 & 4</p>	 <p>Vertical Type SM-4 for Size 0 or 1 Type SM-9 for Size 2 Type SM-11 for Size 3 Type SM-13 for Size 4</p>	 <p>Horizontal Type SM-5 for Size 0 or 1 Type SM-11 for Size 3 Type SM-13 for Size 4</p>	2 2 2 2 2 3 3, 4 4	SM-6 SM-7 SM-8 SM-9 SM-10 SM-11▲ SM-12▲ SM-13▲

* The type SM-2 interlock is factory assembled for horizontal mounting but can easily be converted to vertical mounting. Conversion instructions are included.
† For replacement only on the NEMA Size 00, reversing starters and contactors.
▲ Interlocks do not include mounting pan.



Type SO-11 Overload Relay
Mounting Bracket

Overload Relay Mounting Bracket

Kit Description	Class 9999 Type
Bracket for one overload relay used with horizontal mechanical interlocks, Types SM-1, SM-2, SM-3, SM-6, SM-7 and SM-8	SO-11
Bracket for two overload relays used with vertical mechanical interlocks, Types SM-2, SM-4, SM-5, SM-9 and SM-10	SO-12

AC Two Speed Magnetic Starters Dimensions – Class 8810, 8811, 8812

Non-Reversing — Open Type

Approximate Dimensions

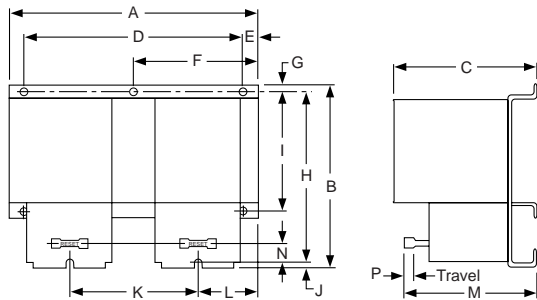

Figure 1
Class 8810, Sizes 0, 1 & 2 Types SBO, SCO & SDO

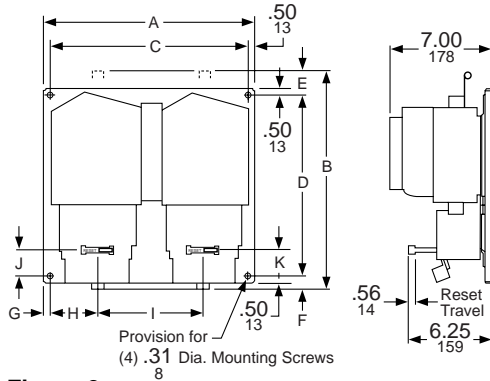

Figure 2
Class 8810, Sizes 3 & 4 Types SEO and SFO

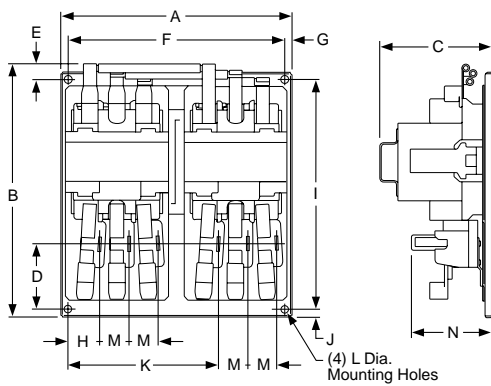

Figure 3
Class 8810, Size 5 Type SGO

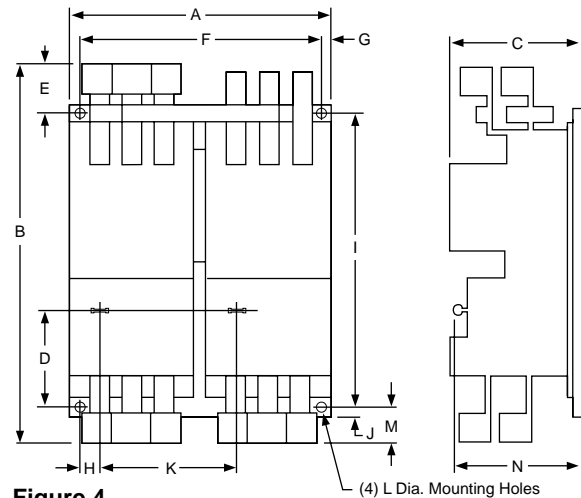

Figure 4
Class 8810, Size 6 Type SHO

Fig. No.	NEMA Size	Type	Mtg. Holes	A		B		C		D		E		F		G		H		I		J		K		L		M		N						
				IN	mm	IN	mm	IN	mm	IN	mm	IN	mm	IN	mm	IN	mm	IN	mm	IN	mm	IN	mm	IN	mm	IN	mm	IN	mm	IN	mm					
1	0 and 1	SBO-1, 2	4	9.63	245	7.34	186	5.31	135	8.00	203	.63	1622	6	6.91	17622	6	4.75	121	2.25	57	5.06	129	.59	15					
		SCO-1, 2	4	9.63	245	7.34	186	5.31	135	8.00	203	.63	1622	6	6.91	17622	6	4.75	121	2.25	57	5.06	129	.59	15					
	SBO-3, 4	3	7.13	181	6.91	176	5.31	135	3.41	87	.47	12	6.22	15822	6	3.56	90	1.63	41	5.06	129	.59	15						
	SCO-3, 4	3	7.13	181	6.91	176	5.31	135	3.41	87	.47	12	6.22	15822	6	3.56	90	1.63	41	5.06	129	.59	15						
2		SDO-1, 2	6	12.03	306	8.53	217	6.03	153	10.38	264	.50	1325	6	8.13	207	6.25	159	.16	4	5.75	146	2.81	71	5.16	131	.78	20					
		SDO-3, 4	3	9.00	229	8.06	205	6.03	153	4.50	114	.38	10	7.50	19119	5	4.34	110	2.16	55	5.16	131	.78	20					
2	3	SEO-1, 2	4	18.00	457	14.44	367	17.00	432	12.25	311	1.50	38	.69	18	.50	13	6.44	164	7.38	187	1.66	42	2.16	55					
		SEO-3, 4	4	12.75	324	12.28	312	11.75	298	10.75	273	1.03	26	.50	13	.50	13	2.50	64	6.75	171	1.16	29	1.16	29					
	SFO-1, 2	4	18.63	473	15.59	396	17.00	432	12.25	311	1.84	47	1.50	38	1.13	29	6.44	164	7.66	195	1.66	42	1.66	42						
	SFO-3, 4	4	14.25	362	14.59	371	13.25	337	12.25	311	1.84	47	.50	13	.50	13	2.94	75	7.38	187	1.66	42	1.66	42						
3	5	SGO-1, 2*	4	29.28	744	20.28	515	9.38	238	5.41	137	1.28	33	28.00	711	.63	16	12.56	319	19.00	483	.63	15	22.53	572	.50	13	2.41	61	6.63	168					
		SGO-3, 4	4	19.28	490	20.28	515	9.38	238	5.14	137	1.28	33	18.00	457	.63	16	2.63	67	19.00	483	.63	15	12.53	318	.50	13	2.41	61	6.63	168					
4	6▲	SHO-1, 2*	4	29.53	750	22.44	570	9.53	242	6.97	177	3.81	97	28.00	711	.75	19	11.63	295	21.19	538	.63	15	9.88	251	.56	14	3.03	77	9.31	236					
		SHO-3, 4	4	19.53	496	22.44	570	9.53	242	6.97	177	3.81	97	18.00	457	.75	19	1.69	43	21.19	538	.63	15	9.88	251	.56	14	3.03	77	9.31	236					
—	7♦	SJO-3, 4	Consult Square D																																	

* Consequent pole, type starters consist of two 3-pole starters as pictured in Figure 3 and an additional 2-pole shorting contactor (not shown), all on a common base-plate, horizontally mounted.

▲ Current transformers used with Size 1 overload relay blocks.

♦ Solid state overloads and special current transformers.



AC Magnetic Starters

Application Data – Class 8810, 8811, 8812

Non-Reversing — Non-Combination — Enclosed

Approximate Dimensions

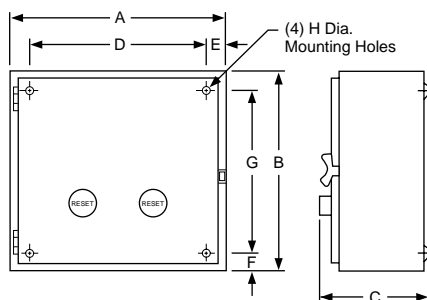

Figure 1

NEMA Type 1 Enclosure – Figure 1

Type	A		B		C		D		E		F		G		H	
	IN	mm	IN	mm	IN	mm	IN	mm	IN	mm	IN	mm	IN	mm	IN	mm
SBG and SCG	11.88	302	11.88	302	7.53	191	9.75	248	1.06	27	1.06	27	9.75	248	.31	8
SDG	14.88	378	14.13	359	7.66	195	12.75	324	1.06	27	1.06	27	12.00	305	.31	8
SEG-3 & -4 and SFG-3 & -4	18.16	461	29.16	741	9.23	234	15.50	394	1.34	34	1.34	34	26.50	673	.44	11
SEG-1 & -2 and SFG-1 & -2	22.16	563	39.16	995	10.23	260	19.50	495	1.34	34	1.34	34	36.50	927	.44	11
SGG-1, 2, 3, 4	20.22	514	65.75	1670	6.45	164	31.00	787	2.13	54	2.13	54	42.00	1067	.56	14
SHG-1, 2, 3, 4	36.22	920	62.22	1580	19.47	495	Floor Mount									
SJG-3 & 4	Consult Square D															

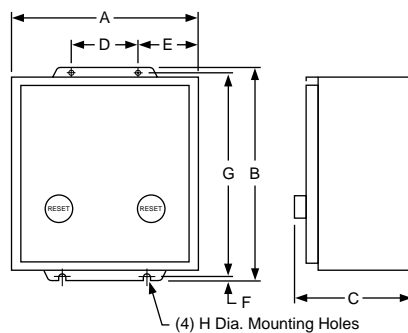

Figure 2

NEMA Type 1 Enclosure – Figure 2

Type	A		B		C		D		E		F		G		H	
	IN	mm	IN	mm	IN	mm	IN	mm	IN	mm	IN	mm	IN	mm	IN	mm
SBA and SCA	11.88	302	13.50	343	7.75	197	4.25	108	3.81	97	.38	10	12.75	324	.31	8
SDA	14.88	378	15.75	400	7.88	200	4.25	108	5.31	135	.38	10	15.00	381	.31	8
SEA-3 & -4 and SFA-3 & -4	18.16	461	31.50	800	9.59	244	16.00	406	3.09	78	.50	13	30.50	775	.44	11
SEA-1 & -2 and SFA-1 & -2	22.16	563	41.50	1054	10.59	269	16.00	406	3.09	78	.50	13	40.50	1029	.44	11
SGA-1, 2, 3, 4	35.22	895	49.00	1245	13.11	333	27.00	686	4.11	104	.50	13	48.00	1219	.56	14
SHA-1, 2, 3, 4	36.22	920	62.22	1580	19.47	495	Floor Mount									
SJA-3 & 4	Consult Square D															



AC Magnetic Starters

Application Data – Class 8810, 8811, 8812

Non-Reversing — Non-Combination — Enclosed

Approximate Dimensions

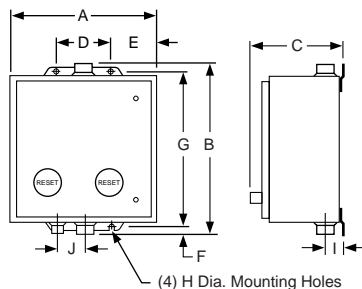

Figure 3

NEMA Type 4 Enclosure – Figure 3

Type	A		B		C		D		E		F		G		H		I		J	
	IN	mm	IN	mm	IN	mm	IN	mm	IN	mm	IN	mm	IN	mm	IN	mm	IN	mm	IN	mm
SBW and SCW	12.63	321	14.69	373	7.81	198	4.25	108	4.19	106	.59	15	13.50	343	.31	8	1.66	42	2.31	59
SDW	14.88	378	15.75	400	8.25	210	4.25	108	5.31	135	.38	10	15.00	381	.31	8	2.03	52	2.63	67
SEW-3 & -4 and SFW-3 & -4	18.16	461	32.22	818	8.77	223	12.00	305	3.08	78	.86	22	30.50	775	.44	11	2.58	66	3.19	81
SEW-1 & -2 and SFW-1 & -2	22.16	563	42.22	1072	9.77	248	16.00	406	3.08	78	.86	22	40.50	1029	.44	11	2.33	59	2.89	73
SGW-1, 2, 3, 4	35.22	895	49.22	1250	12.13	308	27.00	686	4.09	104	.61	15	48.00	1219	.56	14	2.98	76	3.50	89

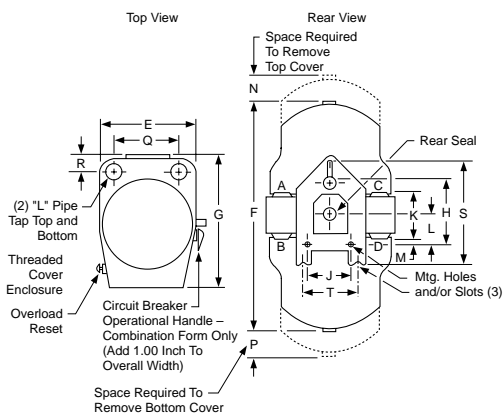

Figure 4

NEMA Type 7 & 9 Enclosure – Figure 4

Type	A		B		C		D		E		F		G		H		J		K		L		M		N		P		R	
	IN	mm	IN	mm	IN	mm	IN	mm	IN	mm	IN	mm	IN	mm	IN	mm	IN	mm	IN	mm	IN	mm	IN	mm	IN	mm	IN	mm		
SCR-1, 2, 3 & 4 Std. & Form Y79-1	12.00	305	41.06	1043	68.06	1729	16.75	425	7.25	184	7.69	195	26.13	664	3.00	76	24.00	610	8.50	216	2.06	52	9.38	238	5.25	133	1.50	38	.38	10
SCR-1, 2, 3 & 4 Forms T & TY79-1	12.00	305	46.13	1172	79.13	2010	16.75	425	12.25	311	7.69	195	26.13	664	9.00	229	24.00	610	8.50	216	2.06	52	9.38	238	5.25	133	1.50	38	.38	10
SDR-1, 2, 3 & 4 Std. & Form Y79-1	16.13	410	48.50	1232	81.50	2070	20.25	514	12.50	318	8.63	219	27.75	705	8.00	203	25.00	635	12.00	305	2.63	67	11.00	279	5.50	140	2.50	64	.38	10
SCR-1, 2, 3 & 4 Forms T & Y79-1	16.13	410	50.50	1283	85.00	2159	20.25	514	9.13	232	8.63	219	32.75	832	4.50	114	30.00	762	12.00	305	2.63	67	11.00	279	5.50	140	2.50	64	.38	10

For Sizes 3, 4 and 5 consult Square D field office.



AC Two Speed Combination Starters

Disconnect Switch or Circuit Breaker Type – Class 8810, 8811, 8812

“Quick Ship Only”

Approximate Dimensions

NEMA Type 1 Enclosure – Figure 1

NEMA Size	Class	Type	Dimensions — Inches/mm																Top & Bottom		Sides
			A	B	C	D	E	F	G	H	I	J	K	L	M	N	O	P	W	X	Y
0-1	8810	SBG SCG	13.88 353	23.13 588	8.25 210	10.63 270	21.00 533	19.28 490	1.88 48	1.88 48	3.75 95	2.31 59	1.06 27	3.30 84	2.19 56	1.25 32	.88 22	...	1/2-3/4-1	1/2-3/4-1	1/2
2	8810	SDG	15.16 385	28.91 734	9.56 243	11.63 295	26.25 667	21.81 554	2.19 56	2.00 51	4.00 102	2.63 67	1.33 34	3.30 84	2.22 56	1.27 32	.91 23	...	1-1/4	1/2-3/4	1/2

NEMA Type 4 Enclosure – Figure 2

NEMA Size	Class	Type	Dimensions — Inches/mm													Bottom	Top & Bottom
			A	B	C	D	E	F	G	H	I	J	K	L	W	X	
0-1	8810	SBW SCW	13.88 353	8.33 212	25.19 640	3.30 84	2.56 65	8.75 222	24.00 610	.59 15	3.95 100	1.63 41	2.31 59	18.53 471	3/4 Hub	1 Hub	
2	8810	SDW	15.13 389	9.58 243	30.94 786	3.30 84	2.56 65	10.00 254	29.75 756	.59 15	3.95 100	2.00 51	2.63 67	21.03 534	3/4 Hub	1 1/2 Hub	

NEMA Type 12 Enclosure – Figure 3

NEMA Size	Class	Type	Dimensions — Inches/mm																			
			A		B		C		D		E		F		G		H		I		J	
			IN	mm	IN	mm	IN	mm	IN	mm	IN	mm	IN	mm	IN	mm	IN	mm	IN	mm	IN	mm
0-1	8810	SBA SCA	13.88	353	10.09	256	24.75	629	3.30	84	2.56	65	8.75	222	24.00	610	.38	10	3.95	100	20.28	515
2	8810	SDA	15.16	385	10.97	279	31.25	794	3.30	84	3.08	78	9.00	229	30.25	768	.50	13	4.83	123	23.44	595

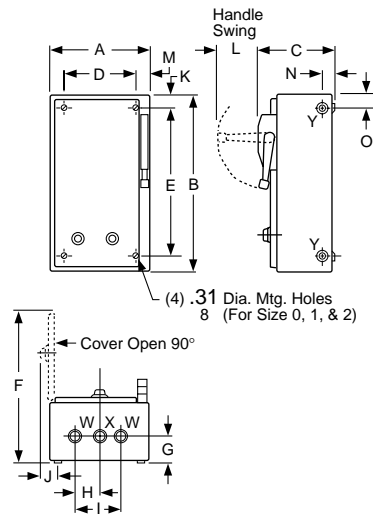

Figure 1
NEMA Type 1 Enclosure

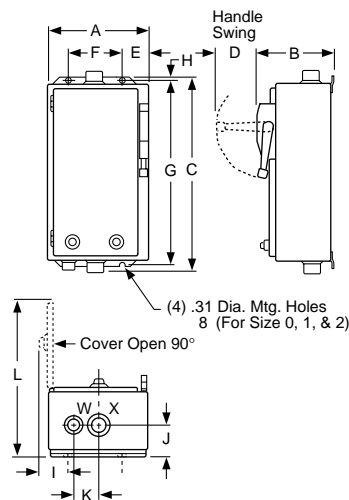

Figure 2
NEMA Type 4 Enclosure

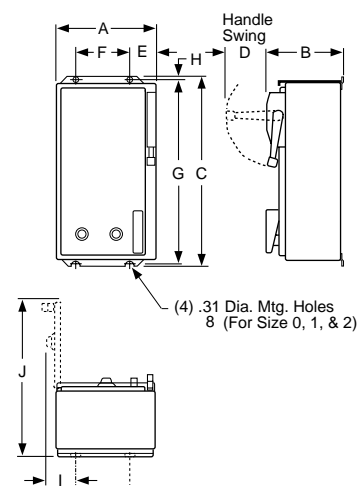



Figure 3
NEMA Type 12 Enclosure



UL is a registered trademark of Underwriters Laboratories, Inc.
CSA is a registered trademark of Canadian Standards Association.
MOTOR LOGIC is a trademark of Square D Company.
Spin Top, Square D and  are registered trademarks of Square D Company.

Catalog No. 8502CT9701 May 1998 © 1998 Square D All Rights Reserved.